



**ERSATZTEILE**

**SPARE PARTS**

**PIÈCES DETACHEES**



000 001 066 00 H - 04/04/2018

**EasyCut 270 CV**

**EasyCut 320 CV**

ab Masch.-Nr.  
from mach.-no.  
à partir de mach.-no

**475 000 - 523 999**

**/ 000 001 066 00 H /**

# Erläuterungen Illustration Illustration

Gültigkeit dieser Tafel  
Validity of this diagram  
Validité du diagramme

Nr. der Zeichnung, die zu dieser Seite gehört  
No. of drawing belonging to this page  
No. du dessin appartenant à cette page

Tafel-Nr.  
No. of diagram  
No. de diagramme

Bennung dieser Tafel  
Denomination of this diagram  
Dénomination du diagramme

Maschinentypen  
Type of machines  
Type de machines

Nr. dieser Ersatzteilliste  
No. of this spare part list  
No. de cette liste des pièces de rechange

Tragrahmen / Schutze kpl. Frame / Guard cpl. Cadre / Protecteurs cpl.						000 001 084 00	
						585 000 - 597 629	444 841 1
							4.0
Pos.	ID-Nr.	Benennung	Description	Description	Masch.-Nr.	Bemerkung/Remarks/Remarque	
1	00 259 671 0	Tragrahmen links	Frame left	Cadre gauche	585 000 - 597 629	x	
	00 259 627 0	Tragrahmen rechts	Frame right	Cadre droite	585 000 - 597 629	x	
	00 901 491 0	6kt-Schraube	Hex head bolt	Boulon tete hex	590 000	x	M 16 X 130
3	00 909 912 0	Sperkantscheibe	Detent edged washer	Disque à bord d'arrêt	597 629	x	SKM 16

Dieses Ersatzteil ist gültig ab Masch.Nr. 590 000  
This spare part is valid from mach. no. 590 000  
Cette pièce de rechange est valable à partir de no. de machine 590 000

Dieses Ersatzteil ist gültig von Masch.Nr. 585 000 bis Masch.Nr. 597 629  
This spare part is valid from mach. no. 585 000 up to mach. no. 597 629  
Cette pièce de rechange est valable à partir de no. de machine 585 000 jusqu'au no. 597 629

Dieses Ersatzteil ist gültig bis Masch.Nr. 597 629  
This spare part is valid up to mach. no. 597 629  
Cette pièce de rechange est valable jusqu'au no. de machine 597 629

Bestell-Nr.  
Order no.  
No. de commande

Position des Ersatzteiles in der Zeichnung  
Position of spare part in the drawing  
Position de la pièce de rechange au dessin

**Ersatzteil-Katalog auch  
auf CD-ROM erhältlich!**  
**Spare parts list also  
available as CD-ROM!**  
**Catalogue de pièces de rechange  
également disponible sur CD-ROM!**

Anzahl Teile je Typ

X = nach Bedarf  
Kein Eintrag = Keine Verwendung für diesen Typ

Quantity of parts for each type

X = as needed  
No entry = No use for this type

Quantité de pièces de chaque type

X = selon besion  
Aucune inscription = Pa d'utilisation pour ce type

INHALTSVERZEICHNIS	TABLE OF CONTENTS	TABLE DES MATIERES	TAFEL DIAGRAM DIAGRAMME
Dreipunktbock / Traghalm Federentlastung / Hydraulik Zettergehäuse Schwadablage	Headstock / beam Spring compensation / Hydraulics Tine conditioner housing Swathlaying	Cadre trois points / bras support Ressort compensateur / Sys. hydraulique Bati du conditionneur Dépose d'andain	1.0 2.0 3.0 4.0
Schutze Zetterwalze Hauptgetriebe Schaltgetriebe	Guard Tine conditioner Main gearbox Transmission	Protecteurs Rouleau conditionneur Carter principal Boîte de vitesses	5.0 6.0 7.0 8.0
Mähholm mit Lagerung Mähholm mit Messerschraubverschluß Mähholm mit Schnellverschluß Hochschnittkufe	Cutter bar with bearings Cutter bar with blade fastening Cutter bar with quick coupler High-cut skid	Lamier avec paliers Lamier avec fixation de couteaux Lamier avec fermeture rapide Sabot coupe haute	9.0 10.0 11.0 11.5
Hauptgelenkwelle Walterscheid Gelenkwelle W 2400_SC-25 Sicherheitsaufkleber Hinweisaufkleber	Main Pto shaft P.T.O shafts Warning signs General information labels	Arbre à cardans primaire Arbre à cardans Plaque indicatrices de securite Plaque indicatrices generales	12.0 13.0 14.0 15.0

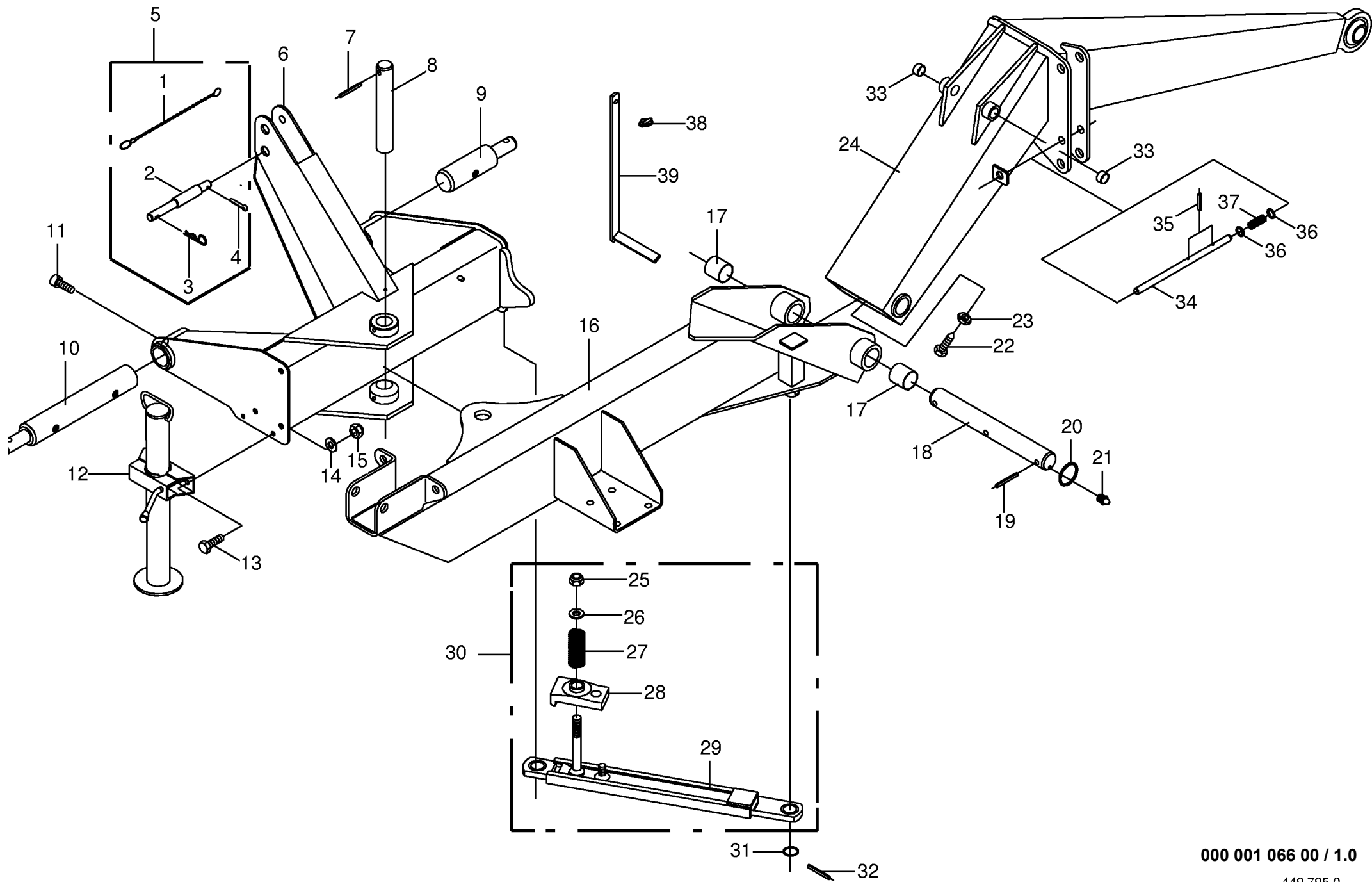

Dreipunktbock / Traghalm Headstock / beam Cadre trois points / bras support						475000 - 523999	E C 2 7 0 C V	E C 3 2 0 C V					000 001 066 00	
													449 795 0	1.0
Pos.	ID-Nr.	Benennung	Description	Description	Masch.-Nr-								Bemerkung/Remarks/Remarque	
1	00 922 650 0	Knotenkette	Chain	Chaîne		x	x						Lg.= 370	
2	00 063 125 0	Oberlenkerbolzen Kat. I + II	Top link pin cat. I + II	Boulon de bras supérieur d'attelage cat. I + II		x	x							
3	00 917 104 1	Federstecker	Spring clip	Goupille elastique		x	x						4	
4	00 912 287 1	Splint	Cotter pin	Goupille fendue		x	x						5 X 32	
5	00 144 141 2	Oberlenkerbolzen -Kat. I + II	Top link pin -cat. I + II	Boulon de bras supérieur d'attelage -cat. I + II		x	x							
6	00 253 551 0	Dreipunktbock	Headstock	Cadre trois points		x	x							
7	00 912 718 2	Spannstift	Roll pin	Goupille de serrage		x	x						10 X 60	
8	00 253 563 0	Bolzen	Pin	Boulon		x	x						Rd. 40 X 270	
9	00 139 474 0	Unterlenkerzapfen -Kat. II	Lower link pin -cat. II	Tourillon d'attelage inferieur -cat. II		x	x						Rd. 50 X 195	
10	00 139 475 0	Unterlenkerzapfen -links	Lower link pin -left	Tourillon d'attelage inferieur		x	x							
11	00 903 205 0	Zylinderschraube	Allen screw	-gauche Vis tête cylindrique		x	x						M 16 X 20	
12	00 938 686 0	Stützfuß	Support jack	Béquille		x	x							
13	00 900 636 0	6kt-Schraube	Hex head bolt	Boulon tête hex		x	x						M 10 X 25	
14	00 910 414 0	Scheibe	Washer	Rondelle		x	x						10,5 X 21 X 2	
15	00 908 758 0	Sicherungsmutter	Locknut	Écrou hex		x	x						M 10	
16	00 253 364 0	Traghalm -inkl. Buchse	Supporting beam -incl. bushing	Bras support -incl. douille		x	x							
17	00 934 954 0	Lagerbuchse	Bearing bush	Coussinet		x	x						45 X 50 X 50	
18	00 253 208 0	Scharnierbolzen	Hinge pin	Boulon de charnière		x	x						Rd. 45 X 367	
19	00 912 500 1	Spannstift	Roll pin	Goupille de serrage		x	x						12 X 65	
20	00 910 899 0	Passscheibe	Shim ring	Rondelle d'ajustage		x	x						45 X 55 X 1	
21	00 919 105 0	Kegelschmiernippel	Grease nipple	Graisser à cone		x	x						AM 8 X 1	
22	00 902 401 0	6kt-Schraube	Hex head bolt	Boulon tête hex		x	x						M 12 X 25	
23	00 908 515 0	6kt-Mutter -niedrige Form	Hex nut -low form	Écrou hex -forme basse		x	x						M 12	
24	00 253 365 0	Auslegearm -inkl. Buchse	Outrigger arm -incl. bushing	Bras de flèche -incl. douille		x	x							
	00 253 366 0	Auslegearm -inkl. Buchse	Outrigger arm -incl. bushing	Bras de flèche -incl. douille		x								
25	00 908 721 0	Sicherungsmutter	Locknut	Écrou hex		x	x						M 20	
26	00 910 649 0	Scheibe	Washer	Rondelle		x	x						21 X 50 X 8	
27	00 139 178 0	Druckfeder	Pressure spring	Ressort de pression		x	x						12,5 X 48 X 96	
28	00 139 054 0	Klinke	Ratchet	Béquille		x	x							
29	00 253 127 0	Pfahlsicherung	Safety break-away	Declenchement de sécurité		x	x							
30	00 253 126 0	Pfahlsicherung -kpl.	Safety break-away -cpl.	Declenchement de sécurité - cpl.		x	x							
31	00 910 516 1	Scheibe	Washer	Rondelle		x	x						33 X 56 X 4	
32	00 912 747 2	Spannstift	Roll pin	Goupille de serrage		x	x						12 X 55	
33	00 934 554 0	Lagerbuchse	Bearing bush	Coussinet		x	x						25 X 28 X 35	
34	00 253 329 0	Verriegelungsbolzen	Locking bolt	Cheville d'arret		x	x						Rd. 16 X 410	

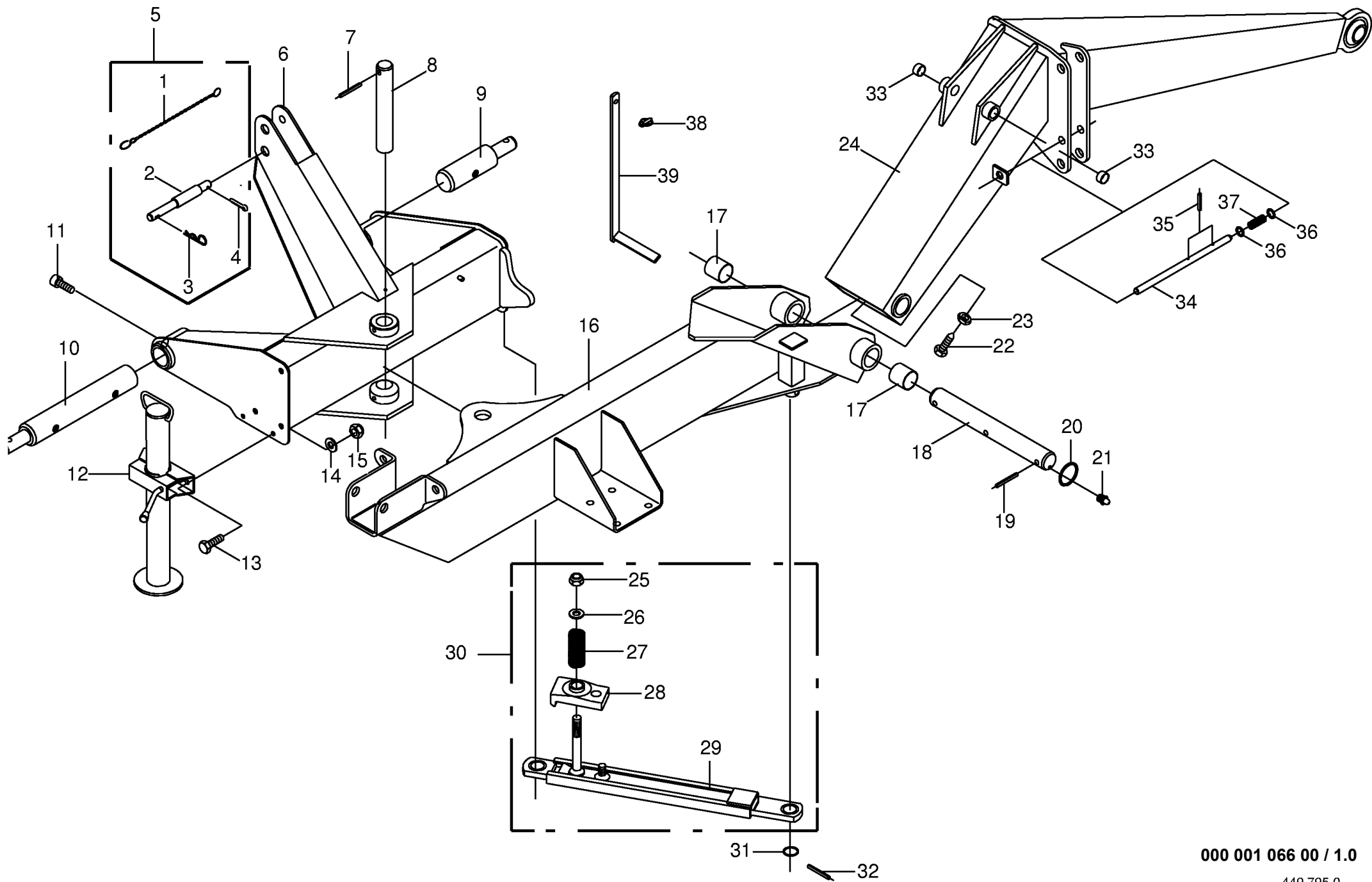



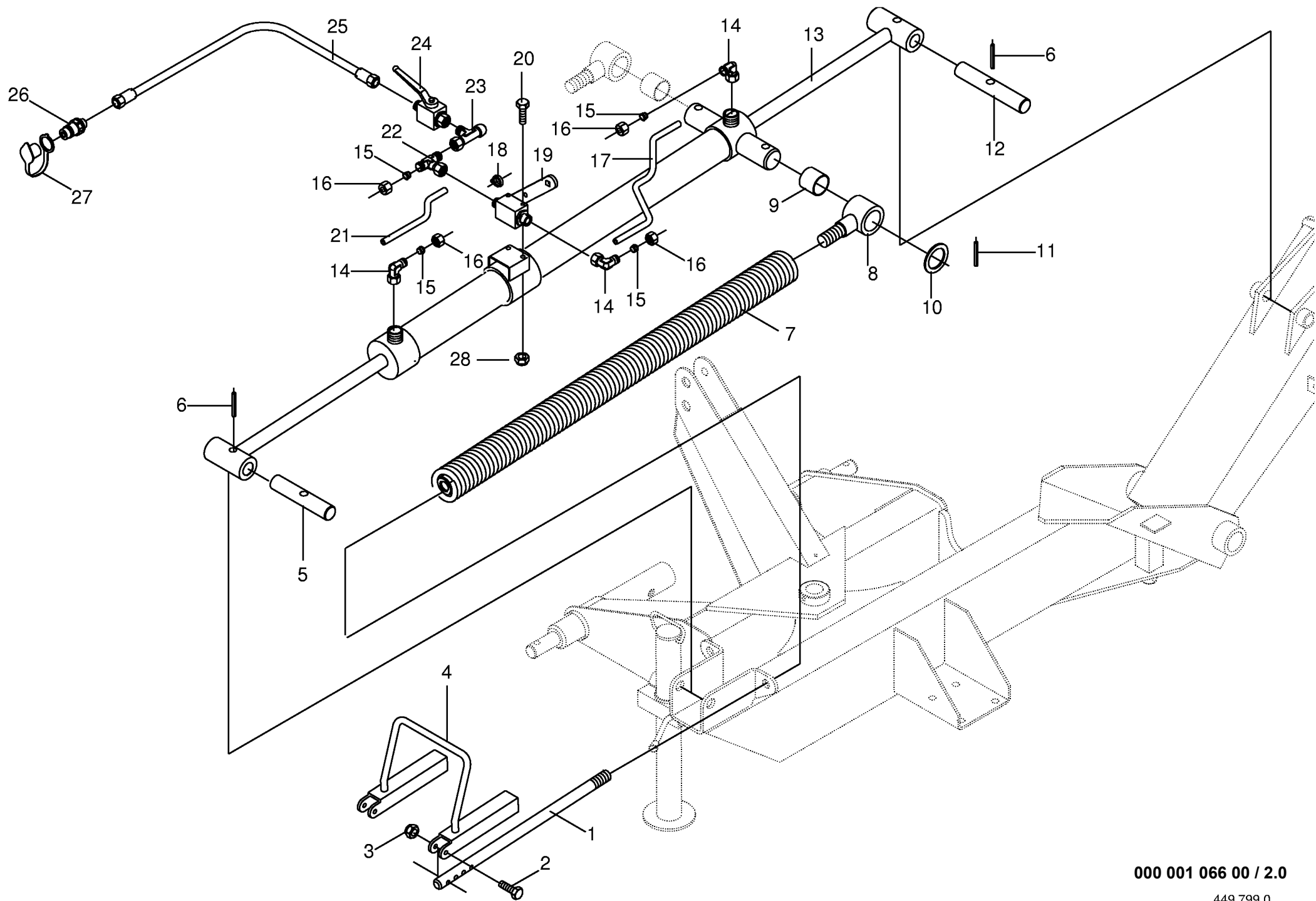



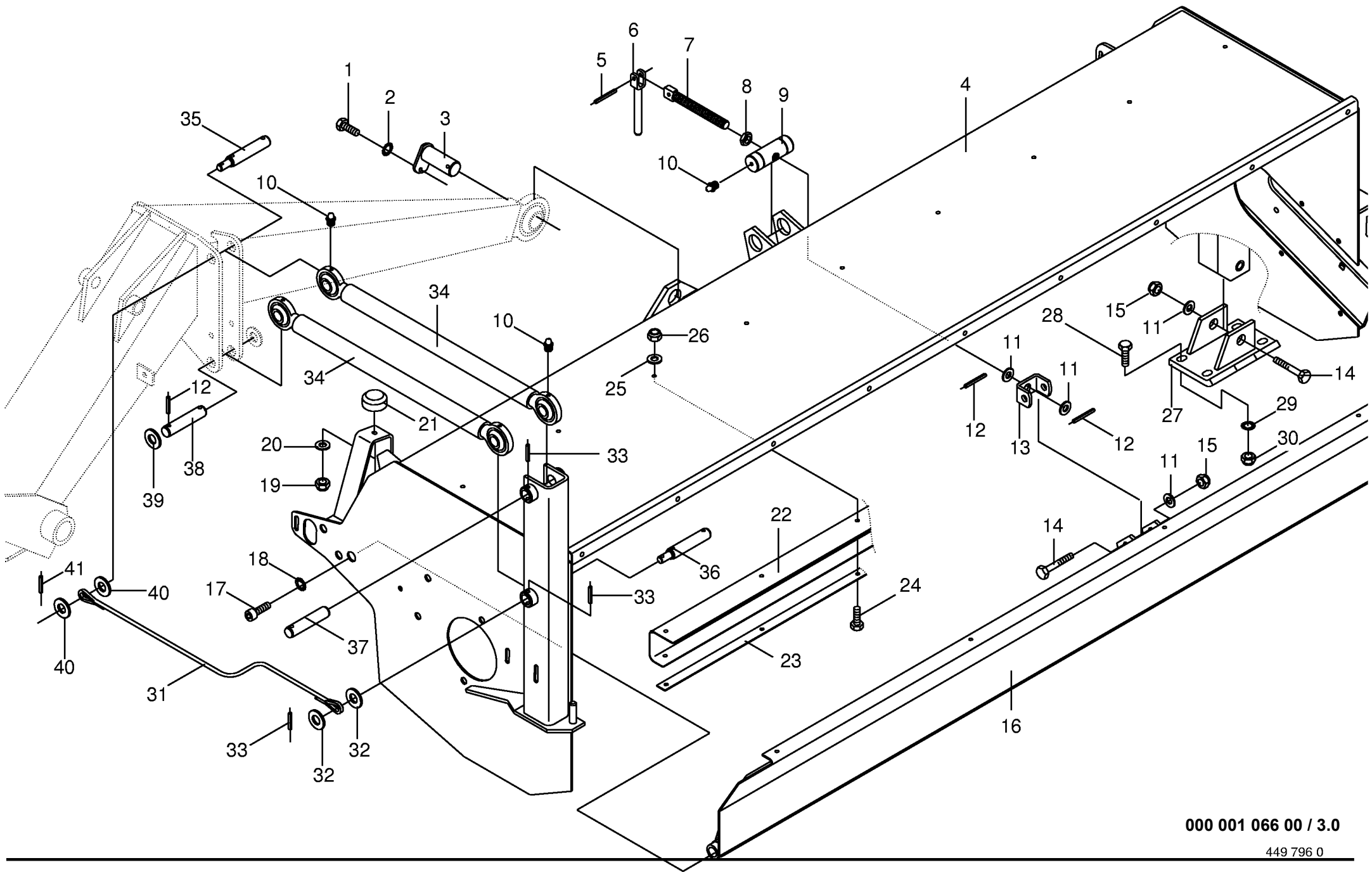

000 001 066 00 / 3.0

449 796 0

Zettergehäuse Tine conditioner housing Bati du conditionneur					475000 - 523999	E C 2 7 0 C V	E C 3 2 0 C V					000 001 066 00	
Pos.	ID-Nr.	Benennung	Description	Description	Masch.-Nr-							449 796 0	3.0
												Bemerkung/Remarks/Remarque	
1	00 900 634 0	6kt-Schraube	Hex head bolt	Boulon tête hex		x	x					M 10 X 20	
2	00 909 909 1	Sperrkantscheibe	Detent edged washer	Disque à bord d'arrêt		x	x					SKM 10	
3	00 253 643 0	Bolzen	Pin	Boulon		x	x						
4	00 253 601 0	Zettergehäuse	Tine conditioner housing	Boîte du conditionneur			x						
5	00 253 401 0	Zettergehäuse	Tine conditioner housing	Boîte du conditionneur		x							
6	00 912 671 2	Spannstift	Roll pin	Goupille de serrage		x	x					8 X 30	
7	00 062 057 1	Griff	Handle	Poignée		x	x						
8	00 253 516 1	Spindel	Spindle	Fuseau		x	x					Lg.= 205	
9	00 908 225 0	6kt-Mutter	Hex nut	Écrou hex		x	x					M 20	
10	00 250 373 0	Mutterstück	Coupling female	Pièce écrou		x	x					Rd. 40 X 110	
11	00 919 105 0	Kegelschmiernippel	Grease nipple	Graisser à cone		x	x					AM 8 X 1	
12	00 910 512 2	Scheibe	Washer	Rondelle		x	x					21 X 37 X 3	
13	00 912 670 1	Spannstift	Roll pin	Goupille de serrage		x	x					8 X 40	
14	00 253 515 1	U-Bügel	U-bow	U-branchon		x	x						
15	00 901 512 0	6kt-Schraube	Hex head bolt	Boulon tête hex		x	x					M 20 X 110	
16	00 908 721 0	Sicherungsmutter	Locknut	Écrou hex		x	x					M 20	
17	00 253 510 1	Riffelblech	Chequered plate	Tôle gaufrée			x						
18	00 256 210 1	Riffelblech	Chequered plate	Tôle gaufrée		x							
19	00 903 205 0	Zylinderschraube	Allen screw	Vis tête cylindrique		x	x					M 16 X 20	
20	00 909 904 1	Sperrkantscheibe	Detent edged washer	Disque à bord d'arrêt		x	x					SKZ 16	
21	00 908 758 0	Sicherungsmutter	Locknut	Écrou hex		x	x					M 10	
22	00 910 414 0	Scheibe	Washer	Rondelle		x	x					10,5 X 21 X 2	
23	00 924 261 0	Gummipuffer	Rubber pad	Tampon en caoutchouc		x	x					Rd. 75 X 25 / M 12	
24	00 256 221 0	Kunststofftuch	Plastic cloth	Toile plastique			x					Lg.= 2488	
25	00 256 223 0	Kunststofftuch	Plastic cloth	Toile plastique		x						Lg.= 2053	
26	00 256 222 0	Klemmband	Clamping strap	Patte de serrage			2					Lg.= 2488	
27	00 256 224 0	Klemmband	Clamping strap	Patte de serrage		2						Lg.= 2053	
28	00 900 614 0	6kt-Schraube	Hex head bolt	Boulon tête hex		x	x					M 8 X 20	
29	00 910 603 0	Scheibe	Washer	Rondelle		x	x					8,4 X 24 X 2	
30	00 908 706 0	Sicherungsmutter	Locknut	Écrou hex		x	x					M 8	
31	00 253 623 0	Platte	Plate	Plaque		x	x						
32	00 901 451 0	6kt-Schraube	Hex head bolt	Boulon tête hex		x	x					M 12 X 45	
33	00 910 506 1	Scheibe	Washer	Rondelle		x	x					13 X 24 X 2,5	
34	00 909 910 1	Sperrkantscheibe	Detent edged washer	Disque à bord d'arrêt		x	x					SKM 12	
35	00 908 701 0	Sicherungsmutter	Locknut	Écrou hex		x	x					M 12	
36	00 253 183 0	Seilzug	Chain haulage	Traction par chaîne		x	x					Lg.= 715	
37	00 910 653 1	Scheibe	Washer	Rondelle		x	x					26 X 44 X 2	
38	00 912 672 1	Spannstift	Roll pin	Goupille de serrage		x	x					8 X 50	

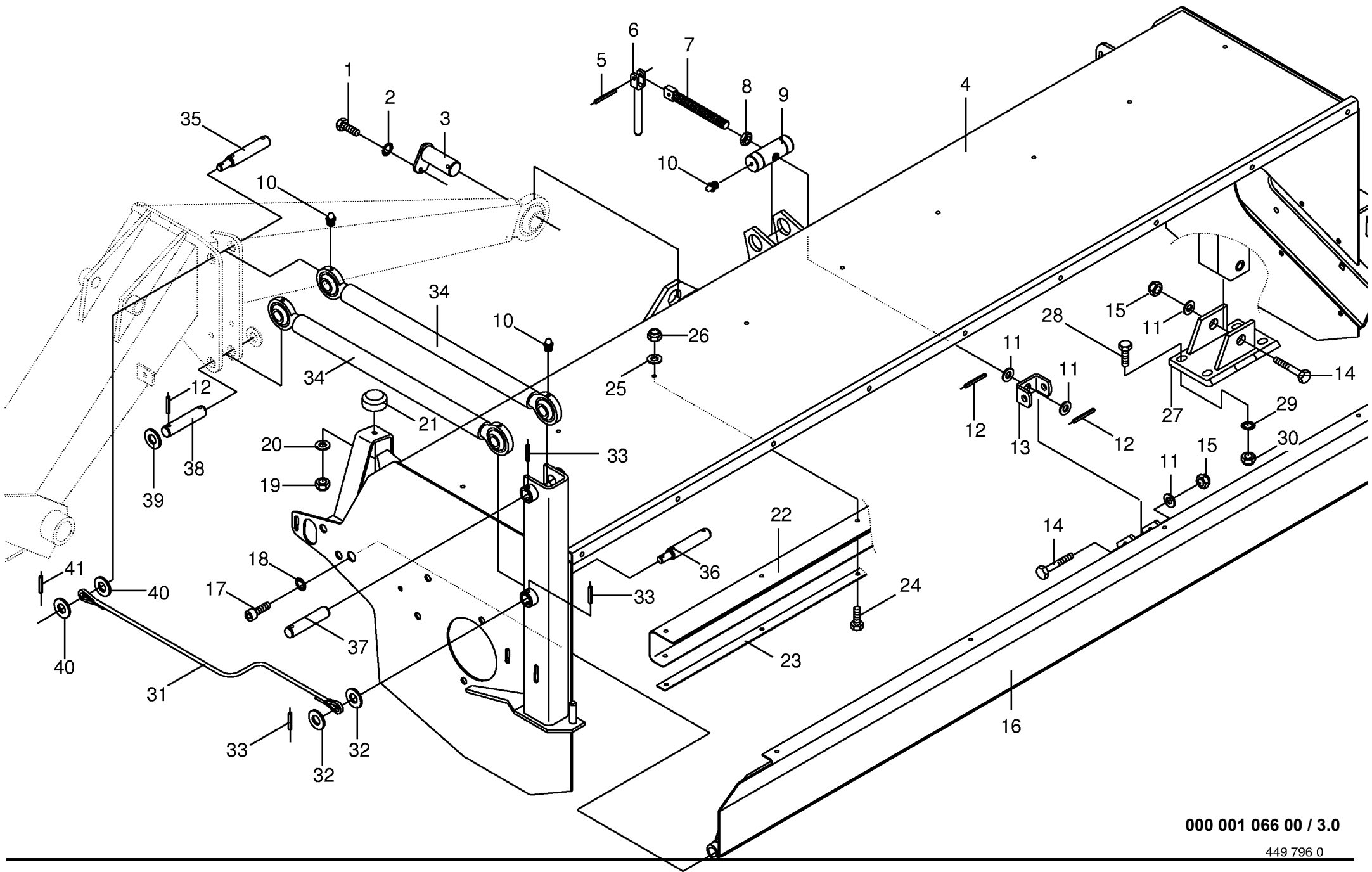

000 001 066 00 / 3.0

449 796 0



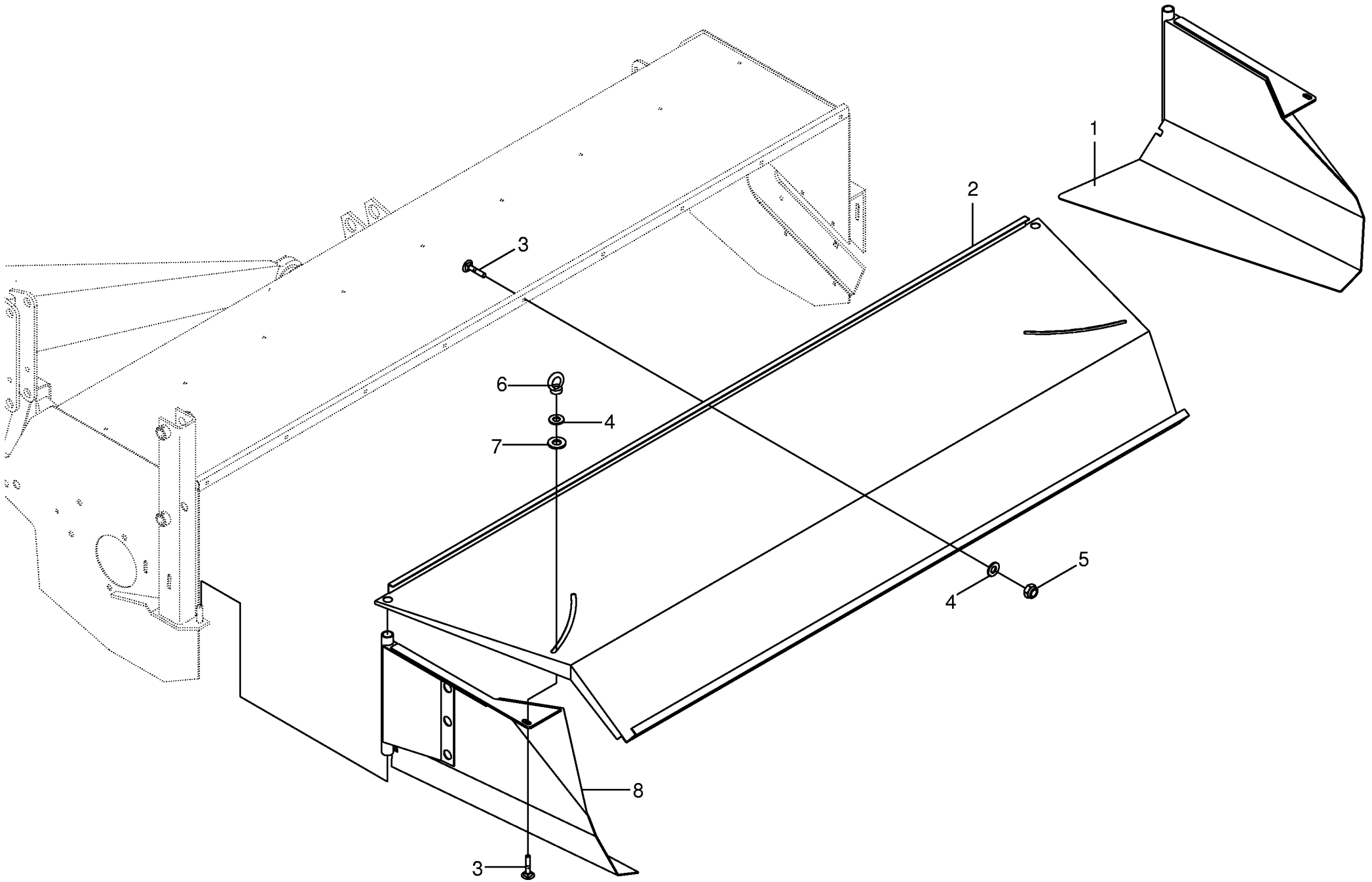

000 001 066 00 / 4.0

449 797 0



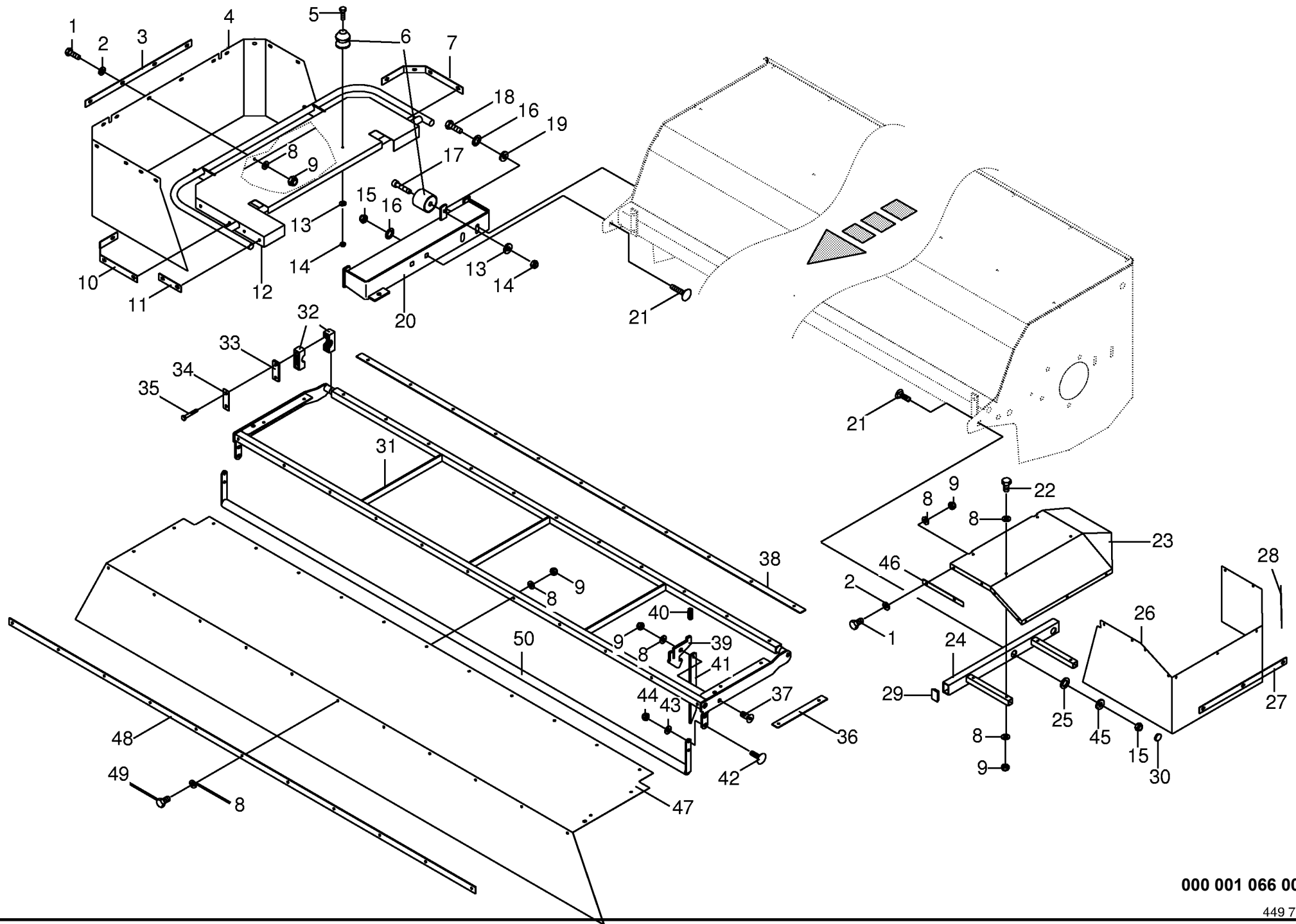

<b>Schutze Guard Protecteurs</b>						475000 - 523999	E C 2 7 0 C V	E C 3 2 0 C V					<b>000 001 066 00</b>
Pos.	ID-Nr.	Benennung	Description	Description	Masch.-Nr-							449 798 0	<b>5.0</b>
												Bemerkung/Remarks/Remarque	
1	00 900 614 0	6kt-Schraube	Hex head bolt	Boulon tête hex		x	x					M 8 X 20	
2	00 910 603 0	Scheibe	Washer	Rondelle		x	x					8,4 X 24 X 2	
3	00 255 329 1	Klemmband	Clamping strap	Patte de serrage		x	x					Lg.= 576	
4	00 255 451 0	Kunststofftuch -rechts	Plastic cloth -right	Toile plastique -droite		x	x					Lg.= 1870	
5	00 901 028 0	6kt-Schraube	Hex head bolt	Boulon tête hex		x	x					M 6 X 30	
6	00 250 831 1	Feststeller und Schnäpper	Clamp and buffer	Touche de blocage et tampon		x	x						
7	00 255 330 1	Klemmband	Clamping strap	Patte de serrage		x	x					Lg.= 403	
8	00 910 413 0	Scheibe	Washer	Rondelle		x	x					8,4 X 17 X 1,6	
9	00 908 706 0	Sicherungsmutter	Locknut	Écrou hex		x	x					M 8	
10	00 255 331 1	Klemmband	Clamping strap	Patte de serrage		x	x					Lg.= 377	
11	00 255 440 1	Klemmband	Clamping strap	Patte de serrage		x	x					Lg.= 120	
12	00 255 319 1	Schutz -rechts	Guard -right	Protecteur -droite		x	x						
13	00 910 351 1	Scheibe	Washer	Rondelle		x	x					6,4 X 18 X 1,6	
14	00 908 704 1	Sicherungsmutter	Locknut	Écrou hex		x	x					M 6	
15	00 908 716 1	Sicherungsmutter	Locknut	Écrou hex		x	x					M 16	
16	00 909 912 1	Sperrkantscheibe	Detent edged washer	Disque à bord d'arrêt		x	x					SKM 16	
17	00 903 045 0	Zylinderschraube	Allen screw	Vis tête cylindrique		x	x					M 6 X 20	
18	00 900 673 0	6kt-Schraube	Hex head bolt	Boulon tête hex		x	x					M 16 X 25	
19	00 910 362 0	Scheibe	Washer	Rondelle		x	x					17 X 40 X 6	
20	00 255 310 0	Schutzkonsole -rechts	Guard console -right	Console de protection -droite		x	x						
21	00 904 708 0	Flachrundschrabe	Coach bolt	Vis à tête bombée		x	x					M 16 X 40	
22	00 901 423 0	6kt-Schraube	Hex head bolt	Boulon tête hex		x	x					M 8 X 50	
23	00 253 646 0	Schutzblech -links	Guard plate -left	Garde-boue -gauche		x	x						
24	00 253 632 0	Schutzträger	Guard support	Support de protecteur		x	x						
25	00 253 363 0	Scheibe	Washer	Rondelle		x	x					30 X 30 X 6	
26	00 253 412 0	Kunststofftuch -links	Plastic cloth -left	Toile plastique -gauche		x	x						
27	00 253 673 0	Klemmband	Clamping strap	Patte de serrage		x	x					Lg.= 450	
28	00 253 671 0	Klemmband	Clamping strap	Patte de serrage		x	x					Lg.= 250	
29	00 925 031 0	Vierkant-Stopfen	Square plug	Bouchon carré		x	x					60 X 40 X 4-5	
30	00 925 017 0	Verschlussstopfen	Sealing plug	Bouchon d'étanchéité		x	x					Rd. 31,8 / 36 X 10	
31	00 253 637 0	Schutzrahmen	Protecting frame	Cadre de protection			x						
	00 253 405 0	Schutzrahmen	Protecting frame	Cadre de protection		x							
32	00 925 104 0	Rohrschelle -2 Hälften	Tube clamp -2 halves	Bride -2 moitiés		x	x					Bo.= 28	
33	00 925 130 0	Deckplatte	Cover plate	Plaque de recouvrement		x	x						
34	00 250 851 0	Sicherungsblech	Locking plate	Tôle de sécurité		x	x						
35	00 901 435 0	6kt-Schraube	Hex head bolt	Boulon tête hex		x	x					M 10 X 60	
36	00 253 672 0	Klemmband	Clamping strap	Patte de serrage		x	x					Lg.= 260	
37	00 904 027 0	Senkschraube	Countersunk screw	Vis à tête fraisée		x	x					M 8 X 35	

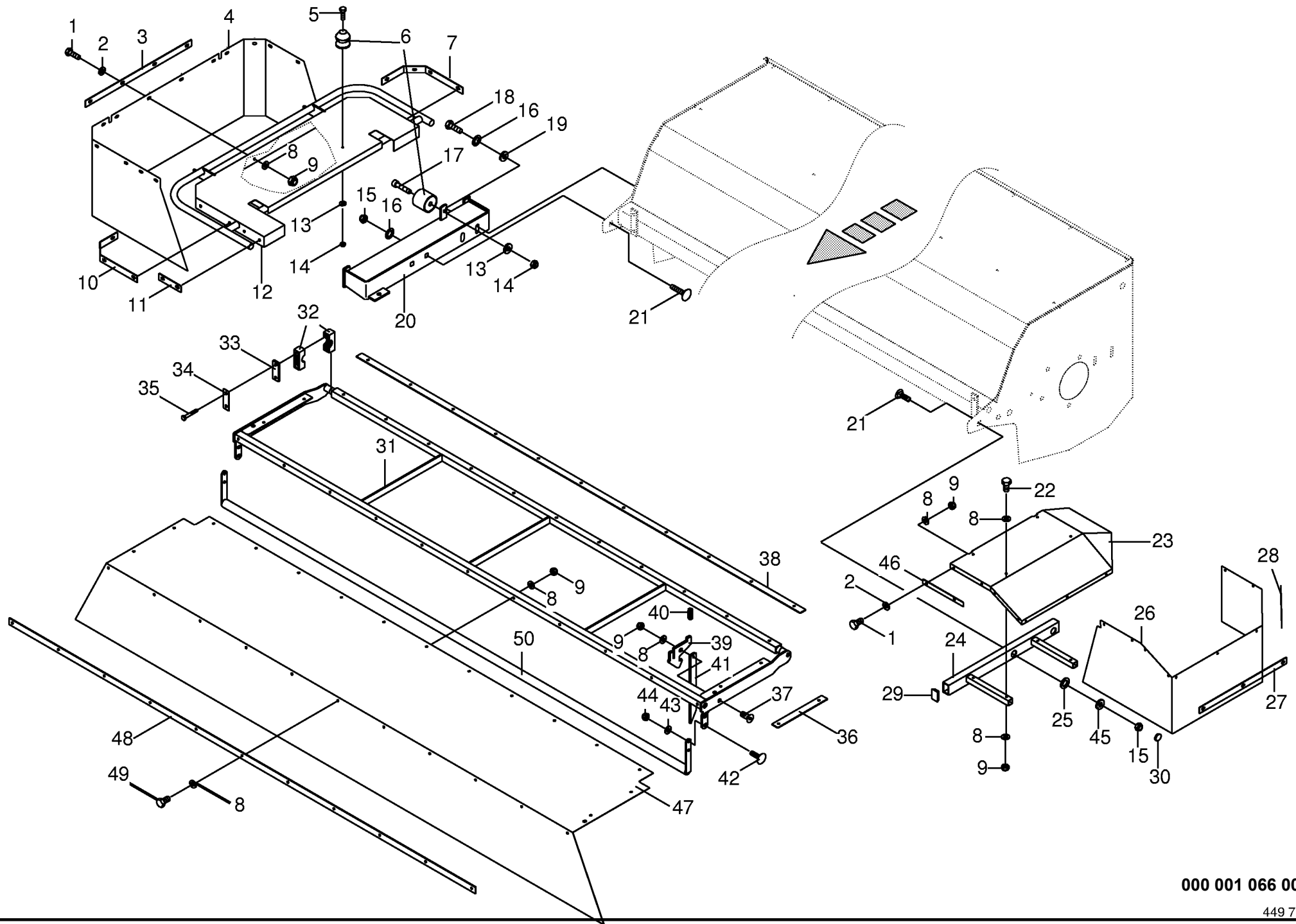



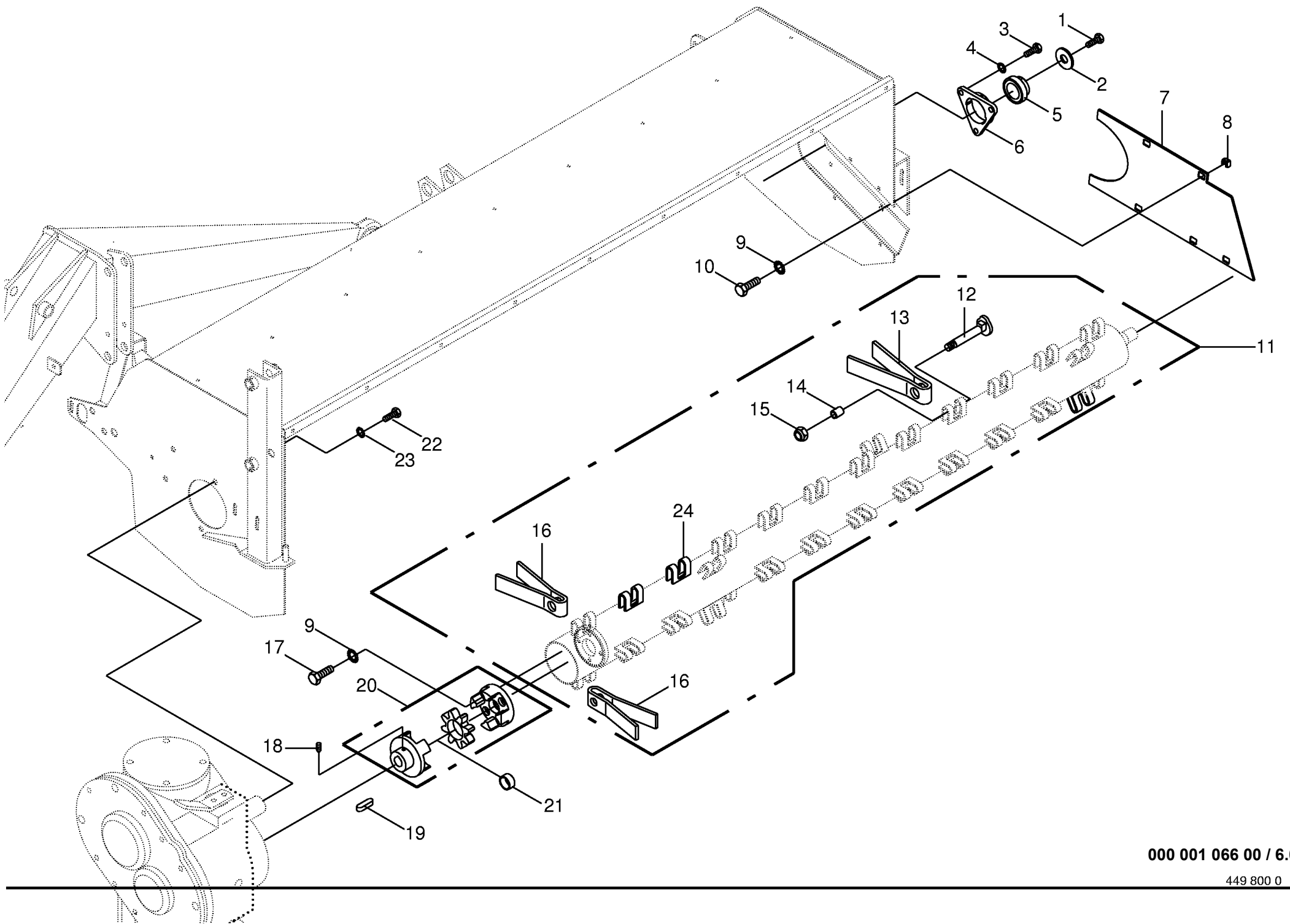



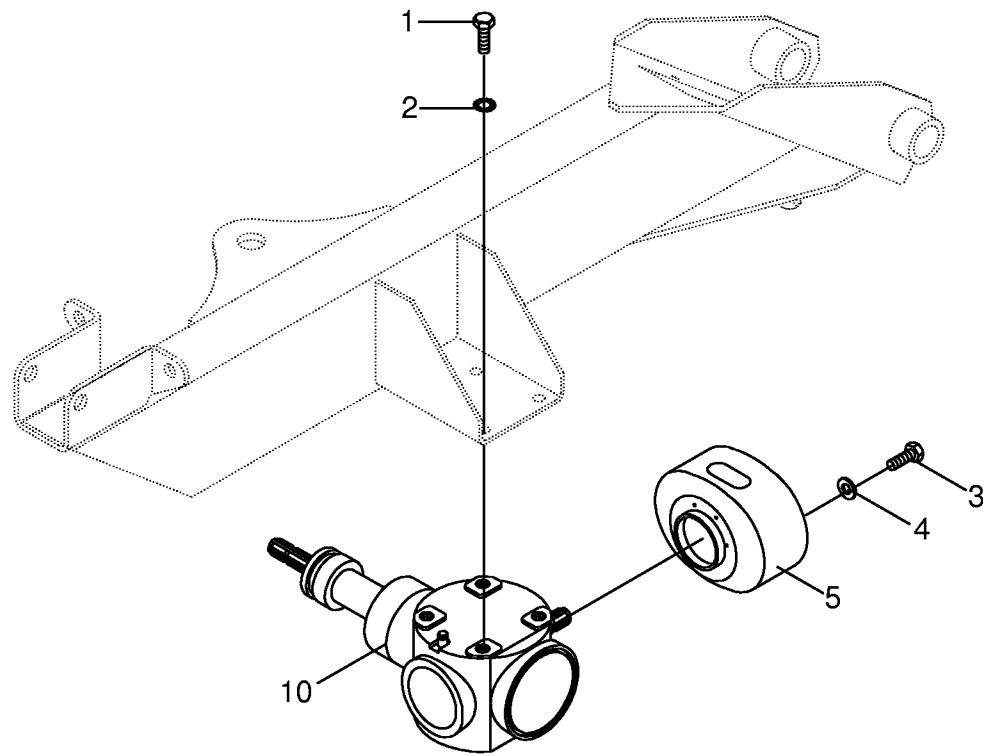



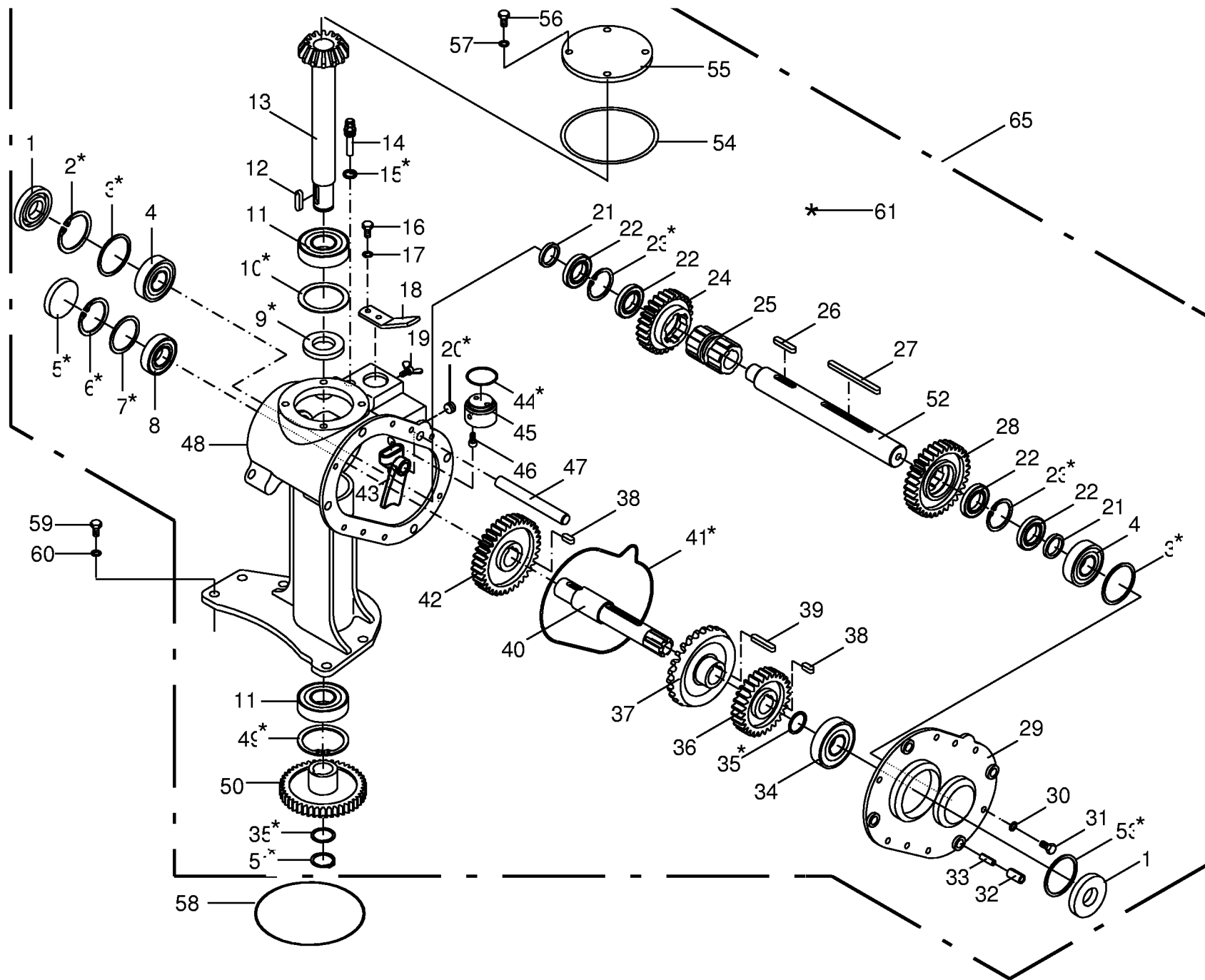

Schaltgetriebe Transmission Boîte de vitesses					475000 - 523999	E C 2 7 0 C V	E C 3 2 0 C V					000 001 066 00	
Pos.	ID-Nr.	Benennung	Description	Description	Masch.-Nr-							449 794 0	8.0
												Bemerkung/Remarks/Remarque	
1	00 936 339 1	Radial-Wellendichtring	Radial-shaft sealing ring	Radial-bague d'étanchéité		x	x					A 35 X 80 X 13	
2	00 911 673 0	Sicherungsring	Circlip	Circlip		x	x					80 X 2,5	
3	00 911 022 0	Passscheibe	Shim ring	Rondelle d'ajustage		x	x					70 X 80 X 0,1	
	00 911 023 0	Passscheibe	Shim ring	Rondelle d'ajustage		x	x					70 X 80 X 0,3	
4	00 911 024 0	Passscheibe	Shim ring	Rondelle d'ajustage		x	x					70 X 80 X 1,0	
	00 930 167 0	Rillenkugellager	Grooved ball bearing	Roulement à gorge		x	x					6307	
5	00 925 203 0	Verschlussdeckel	Sealing cap	Couvercle de fermeture		x	x					Rd. 72	
6	00 911 668 0	Sicherungsring	Circlip	Circlip		x	x					72 X 2,5	
7	00 911 160 0	Passscheibe	Shim ring	Rondelle d'ajustage		x	x					60 X 72 X 0,1	
	00 911 162 0	Passscheibe	Shim ring	Rondelle d'ajustage		x	x					60 X 72 X 0,3	
	00 911 164 0	Passscheibe	Shim ring	Rondelle d'ajustage		x	x					60 X 72 X 1,0	
8	00 930 137 0	Rillenkugellager	Grooved ball bearing	Roulement à gorge		x	x					6207	
9	00 936 359 0	Radial-Wellendichtring	Radial-shaft sealing ring	Radial-bague d'étanchéité		x	x					A 40 X 72 X 10	
	00 910 970 0	Passscheibe	Shim ring	Rondelle d'ajustage		x	x					70 X 90 X 0,1	
	00 910 972 0	Passscheibe	Shim ring	Rondelle d'ajustage		x	x					70 X 90 X 0,3	
	00 910 973 0	Passscheibe	Shim ring	Rondelle d'ajustage		x	x					70 X 90 X 0,5	
11	00 930 568 0	Rillenkugellager	Grooved ball bearing	Roulement à gorge		x	x					6308 2RS	
12	00 915 122 0	Passfeder	Fit-in key	Clavette		x	x					A 10 X 8 X 40	
13	00 256 186 0	Ritzelwelle	Pinion shaft	Arbre de pignon		x	x					Z= 14	
14	00 919 829 0	Belüftungsfilter	Breather	Reniflard		x	x					M 18 X 1,5	
15	00 937 727 0	Dichtring	Gasket ring	Bague d'étanchéité		x	x					A 18 X 24	
16	00 900 614 0	6kt-Schraube	Hex head bolt	Boulon tête hex		x	x					M 8 X 20	
17	00 909 908 1	Sperrkantscheibe	Detent edged washer	Disque à bord d'arrêt		x	x					SKM 8	
18	00 256 113 0	Schalthebel	Actuating lever	Levier		x	x						
19	00 906 132 0	Flügelschraube	Winged screw	Vis à oreilles		x	x					M 8 X 16	
20	00 906 040 1	Verschlusschraube	Screw plug	Bouchon fileté		x	x					M 18 X 1,5	
21	00 139 427 0	Distanzscheibe	Spacing washer	Rondelle entretoise		x	x						
22	00 930 103 0	Rillenkugellager	Grooved ball bearing	Roulement à gorge		x	x					160 07	
23	00 911 659 0	Sicherungsring	Circlip	Circlip		x	x					62 X 2,0	
24	00 256 191 0	Stirnrad	Spur gear	Roue d'engrenage		x	x					Z= 27	
25	00 256 104 0	Schaltnuffe	Shifter collar	Manchon de commande		x	x						
26	00 915 016 0	Passfeder	Fit-in key	Clavette		x	x					C 10 X 8 X 50	
27	00 915 017 0	Passfeder	Fit-in key	Clavette		x	x					A 10 X 8 X 125	
28	00 256 192 0	Stirnrad	Spur gear	Roue d'engrenage		x	x					Z= 33	
29	00 256 189 0	Getriebedeckel	Gearbox cover	Couvercle du boîte de vitesses		x	x						
30	00 909 909 1	Sperrkantscheibe	Detent edged washer	Disque à bord d'arrêt		x	x					SKM 10	
31	00 900 636 0	6kt-Schraube	Hex head bolt	Boulon tête hex		x	x					M 10 X 25	
32	00 912 508 0	Spannstift	Roll pin	Goupille de serrage		x	x					16 X 30	

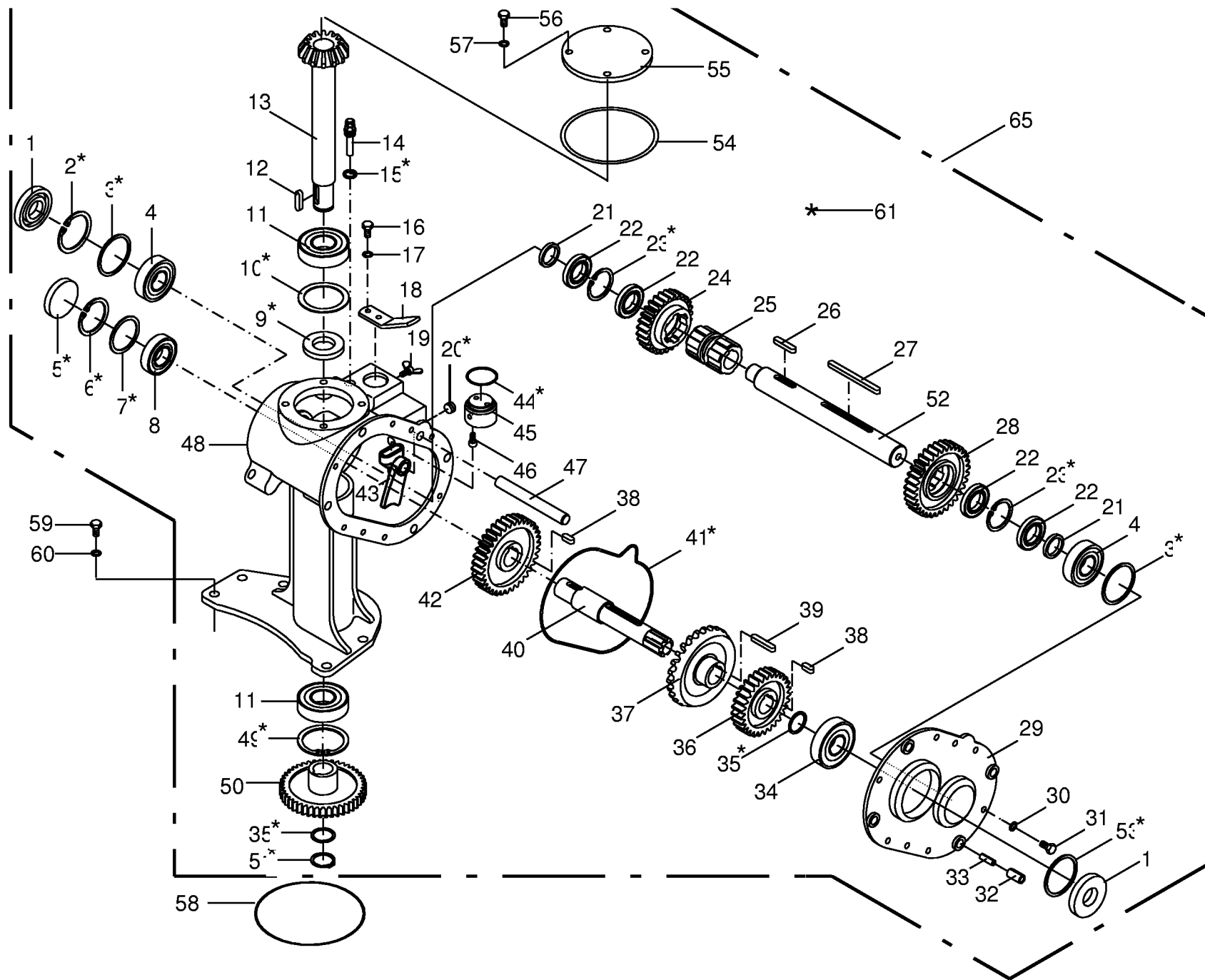

Schaltgetriebe Transmission Boîte de vitesses						475000 - 523999	E C 2 7 0 C V	E C 3 2 0 C V					000 001 066 00
Pos.	ID-Nr.	Benennung	Description	Description	Masch.-Nr-							449 794 0	8.0
												Bemerkung/Remarks/Remarque	
33	00 912 711 0	Spannstift	Roll pin	Goupille de serrage		x	x					10 X 30	
34	00 930 338 0	Rillenkugellager	Grooved ball bearing	Roulement à gorge		x	x					6407	
35	00 911 130 0	Passscheibe	Shim ring	Rondelle d'ajustage		x	x					35 X 45 X 0,1	
	00 911 132 0	Passscheibe	Shim ring	Rondelle d'ajustage		x	x					35 X 45 X 0,3	
	00 911 133 0	Passscheibe	Shim ring	Rondelle d'ajustage		x	x					35 X 45 X 0,5	
	00 911 134 0	Passscheibe	Shim ring	Rondelle d'ajustage		x	x					35 X 45 X 1,0	
	00 911 136 1	Passscheibe	Shim ring	Rondelle d'ajustage		x	x					35 X 45 X 2,0	
36	00 256 193 0	Stirnrad	Spur gear	Roue d'engrenage		x	x					Z= 29	
37	00 256 187 1	Tellerrad	Crown wheel	Grande couronne		x	x					Z= 26	
38	00 915 105 0	Passfeder	Fit-in key	Clavette		x	x					B 10 X 8 X 25	
39	00 915 001 0	Passfeder	Fit-in key	Clavette		x	x					A 10 X 8 X 56	
40	00 253 168 0	Antriebswelle	Drive shaft	Arbre d'entraînement		x	x						
41	00 937 583 0	O-Ring	O-ring	Joint torique		x	x					258 X 4	
42	00 256 194 0	Stirnrad	Spur gear	Roue d'engrenage		x	x					Z= 35	
43	00 256 109 2	Schaltfinger	Shift finger	Doigt de commande		x	x						
44	00 937 500 0	O-Ring	O-ring	Joint torique		x	x					55,2 X 3	
45	00 256 111 3	Exzenter	Excentric	Excentré		x	x						
46	00 903 073 1	Zylinderschraube	Allen screw	Vis tête cylindrique		x	x					M 8 X 16	
47	00 256 112 0	Schaltstange	Operation pole	Perche isolante		x	x					Lg.= 167.5	
48	00 256 101 2	Schaltgetriebegehäuse	Indexing gear housing	Carter dechangement de vitesse		x	x						
49	00 911 680 0	Sicherungsring	Circlip	Circlip		x	x					90 X 3	
50	00 253 034 2	Stirnrad	Spur gear	Roue d'engrenage		x	x					Z= 44	
51	00 911 541 0	Sicherungsring	Circlip	Circlip		x	x					A 35 X 1,5	
52	00 256 103 0	Zetterantriebswelle	Conditioner drive shaft	Arbre d'entraînement de conditionneur		x	x					35 X 372	
53	00 910 993 0	Passscheibe	Shim ring	Rondelle d'ajustage		x	x					80 X 100 X 0,5	
	00 910 992 0	Passscheibe	Shim ring	Rondelle d'ajustage		x	x					80 X 100 X 0,3	
54	00 937 581 0	O-Ring	O-ring	Joint torique		x	x					105 X 3,0	
55	00 256 173 0	Getriebedeckel	Gearbox cover	Couvercle du boîte de vitesses		x	x						
56	00 900 655 0	6kt-Schraube	Hex head bolt	Boulon tête hex		x	x					M 12 X 25	
57	00 909 910 1	Sperrkantscheibe	Detent edged washer	Disque à bord d'arrêt		x	x					SKM 12	
58	00 936 568 0	O-Ring	O-ring	Joint torique		x	x					154 X 3	
59	00 900 675 0	6kt-Schraube	Hex head bolt	Boulon tête hex		x	x					M 16 X 40	
60	00 909 912 1	Sperrkantscheibe	Detent edged washer	Disque à bord d'arrêt		x	x					SKM 16	
61	00 256 015 1	Reparatur-Set -inkl. Pos. *	Repair kit -incl. Pos. *	Kit de reparartion -incl. Pos. *		x	x						
65	00 253 170 0	Schaltgetriebe -kpl.	Indexing gear -cpl.	Changement de vitesse -cpl.		x	x						
	00 926 101 0	Getriebeöl -Id.-Nr.= 1ltr	Oil -Id.-no.= 1ltr	Huile -Id.-no.= 1ltr		1,5	1,5						

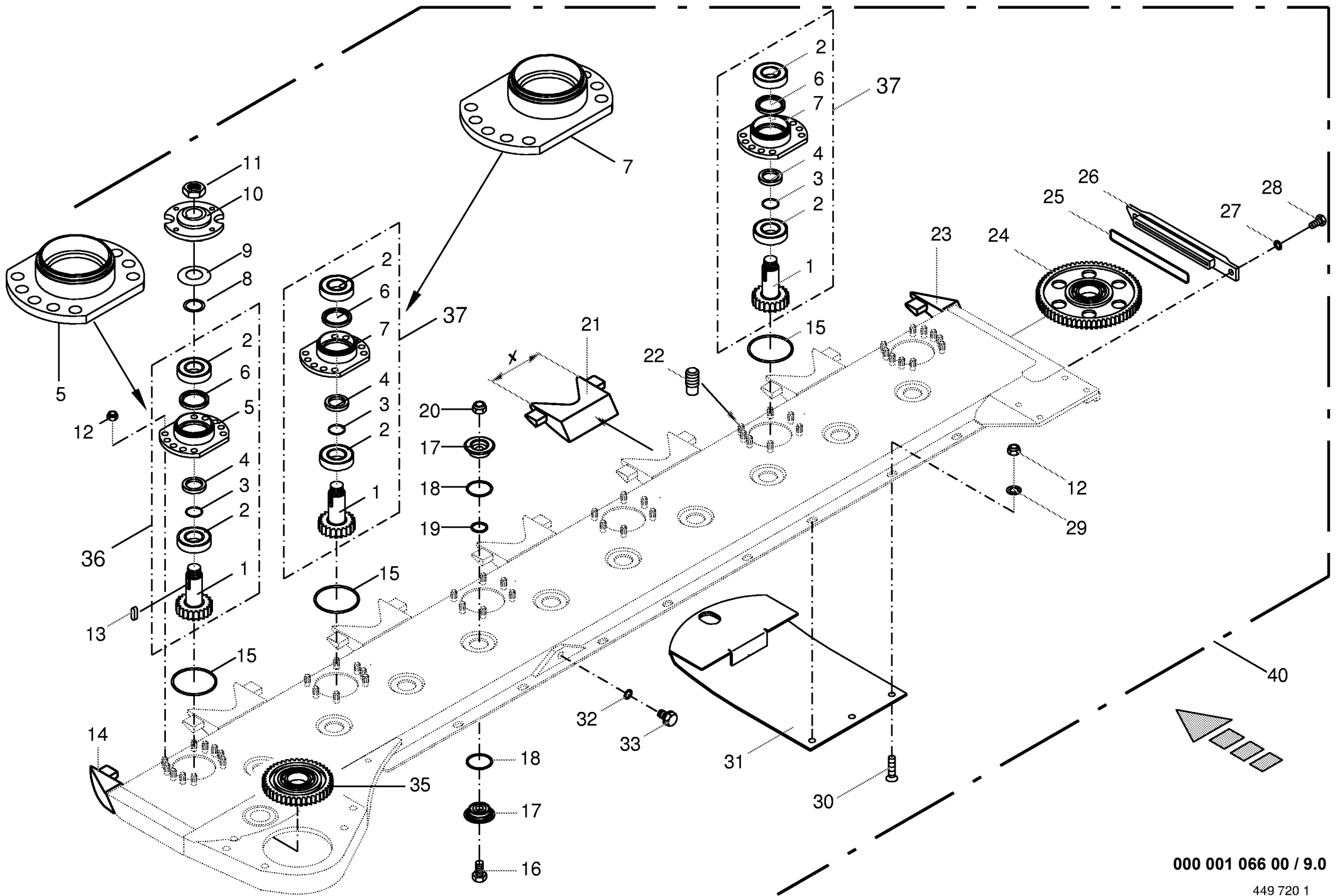



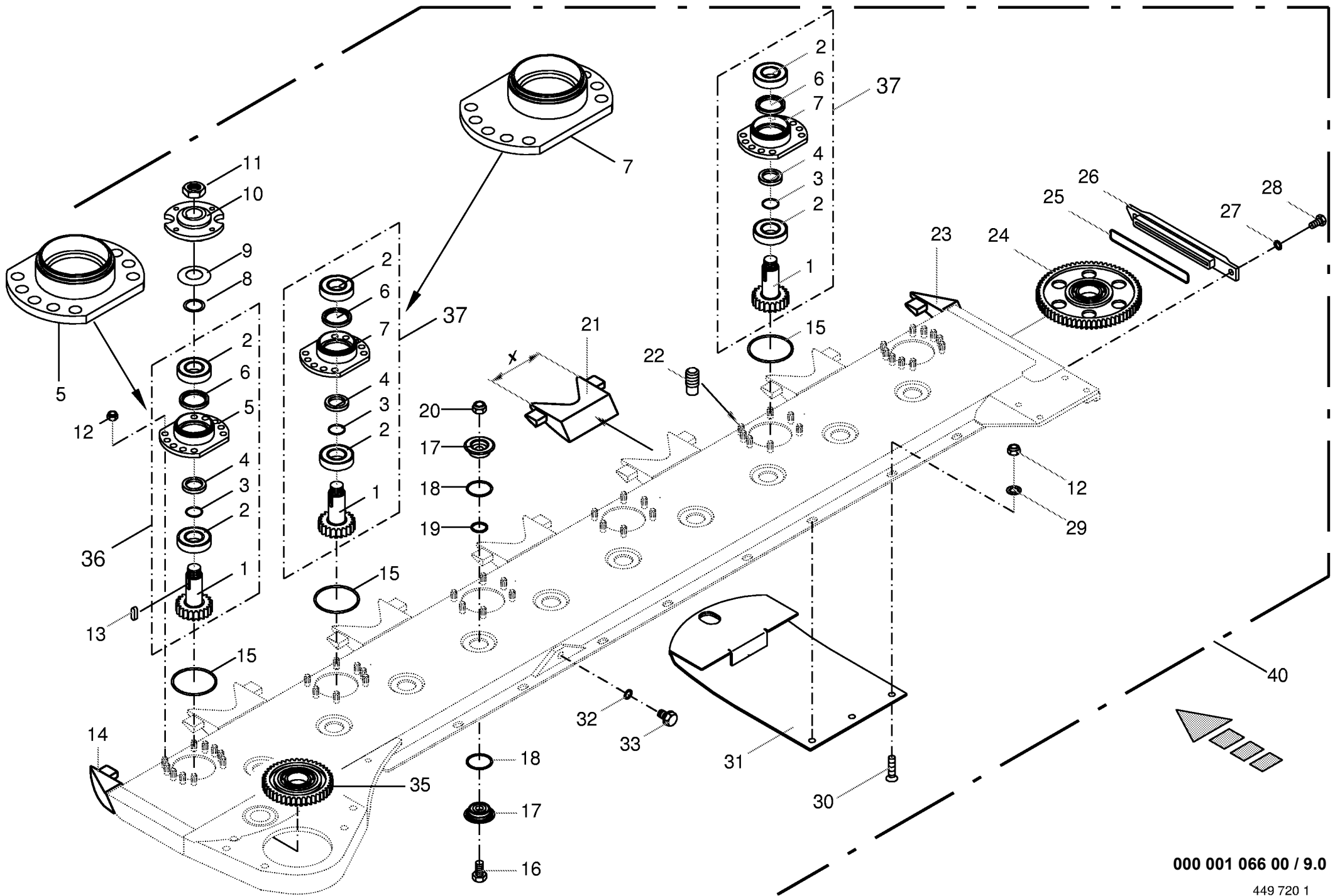



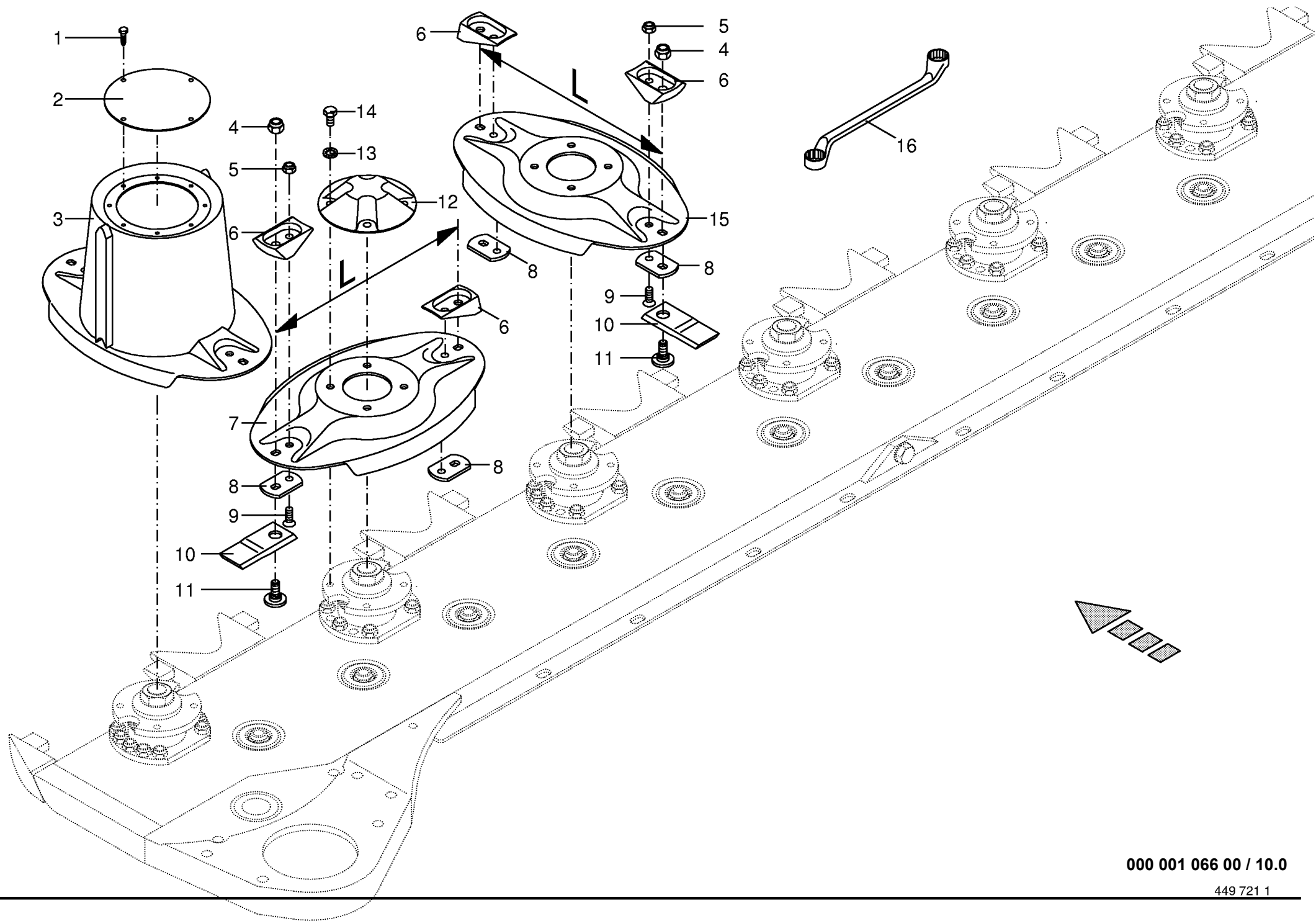



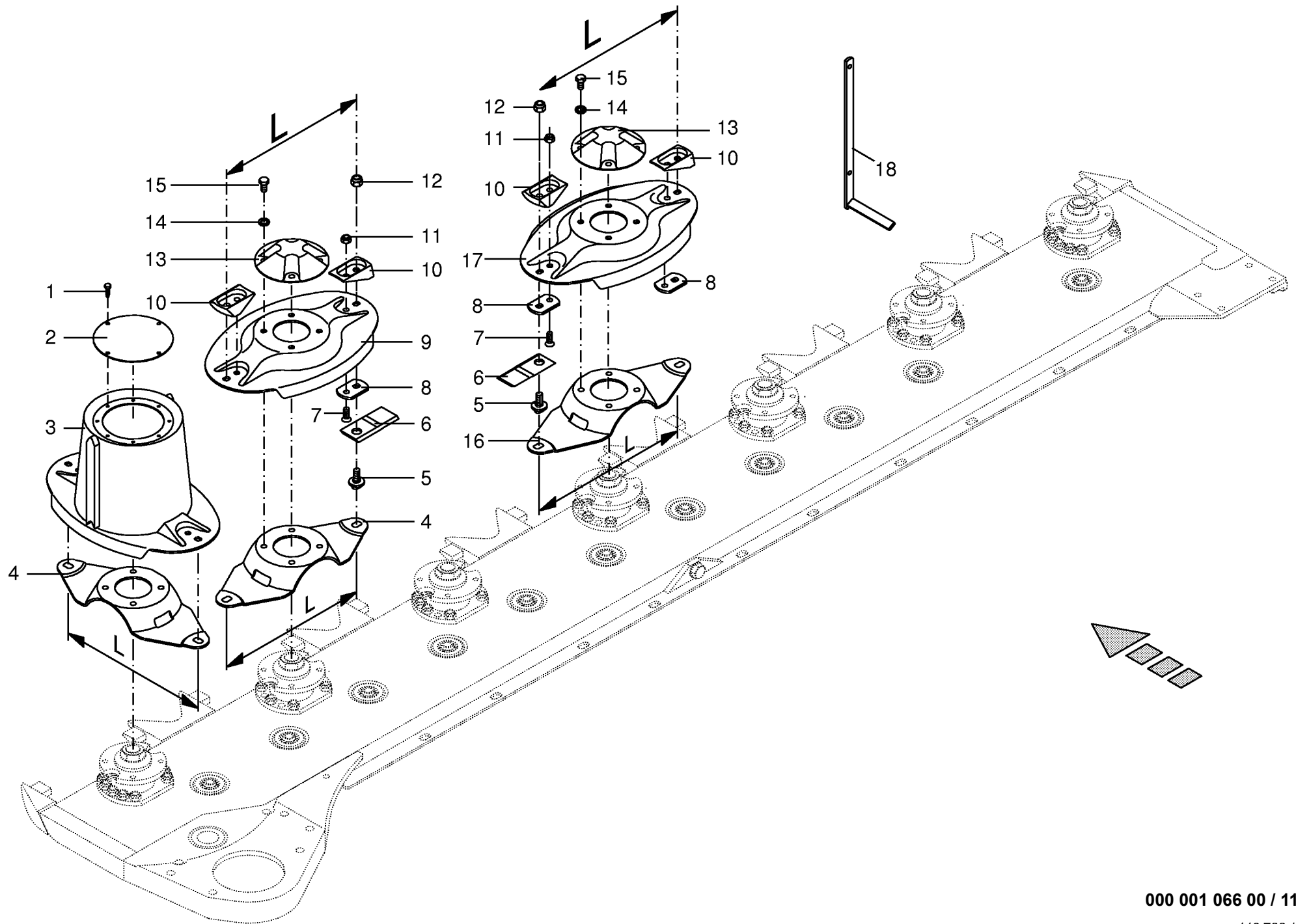



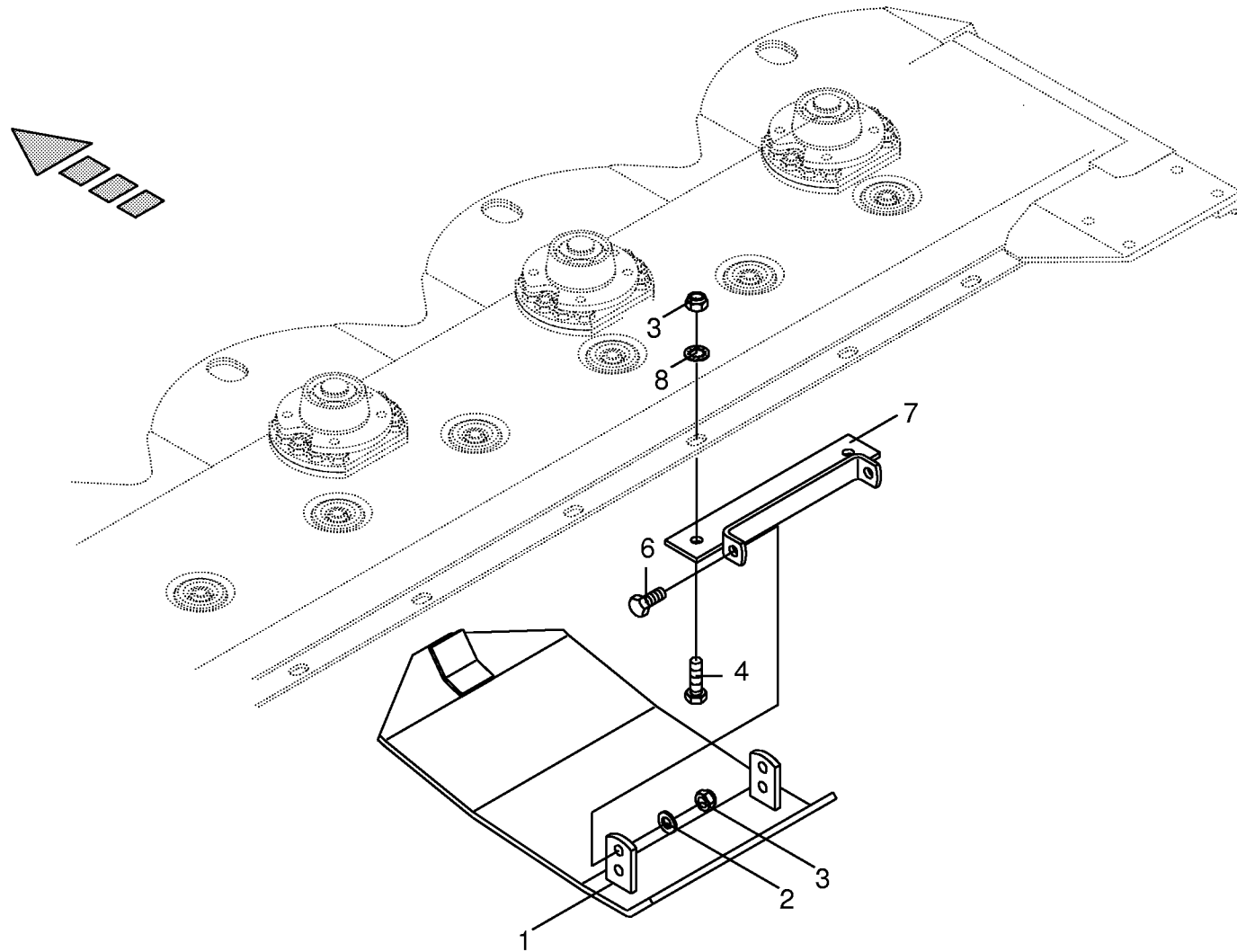



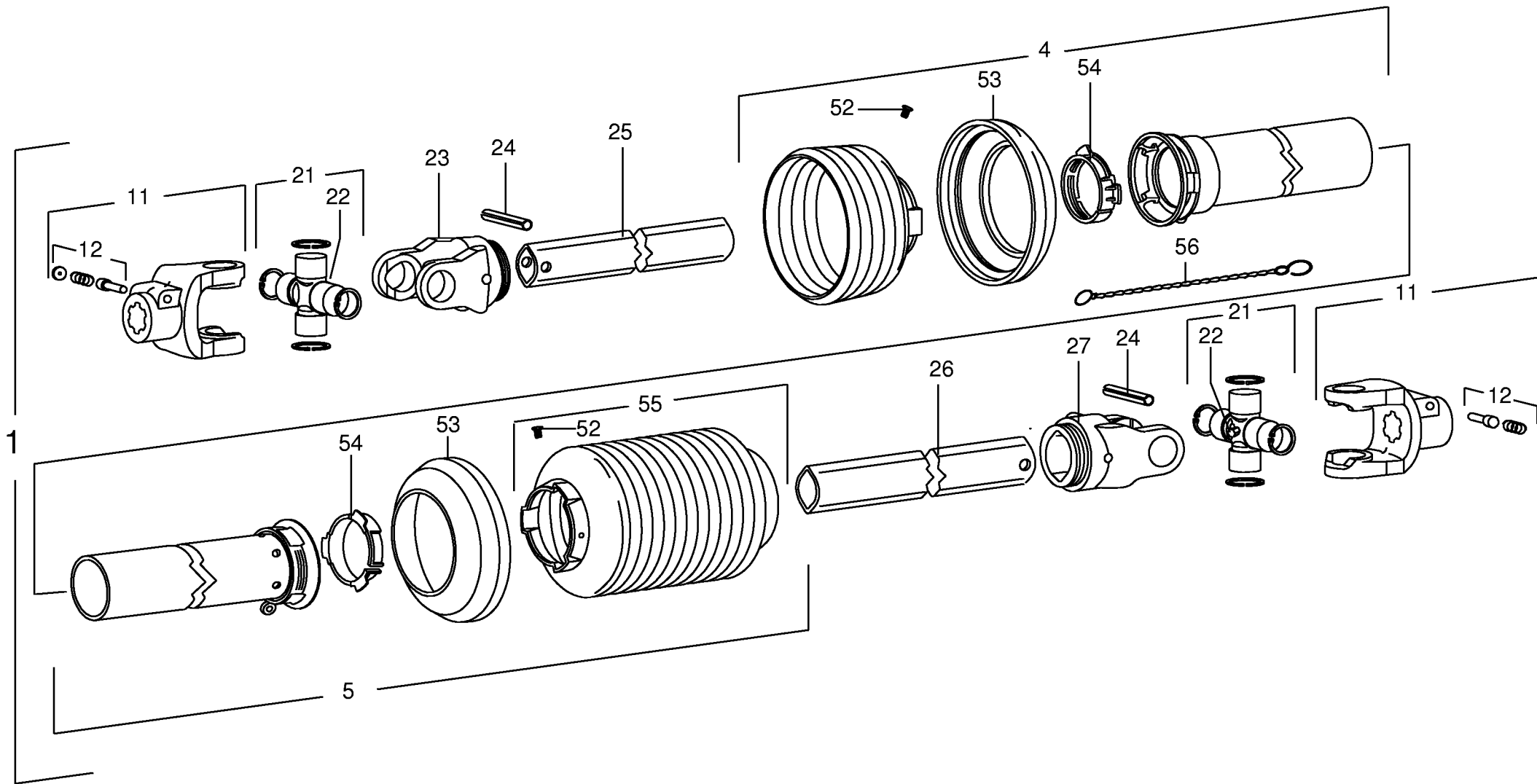



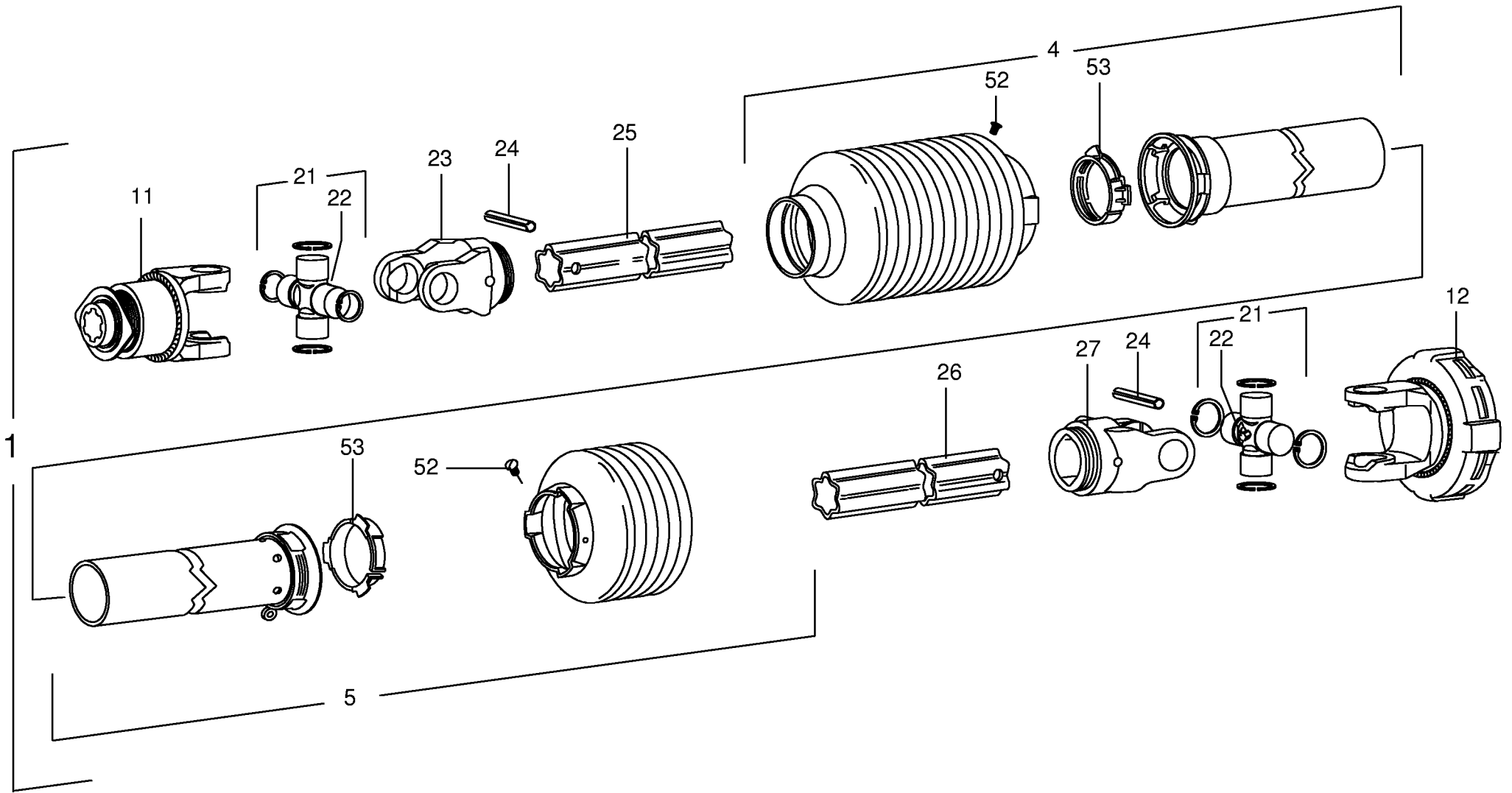



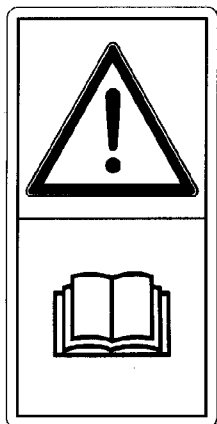

1

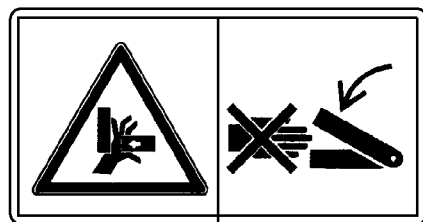

2

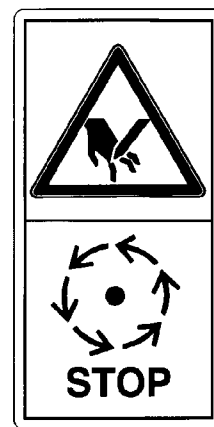

3



4



5

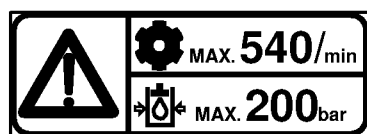

6

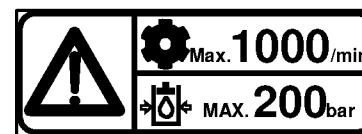

7



# EASYCUT 270 CV

1

# KRONE

2

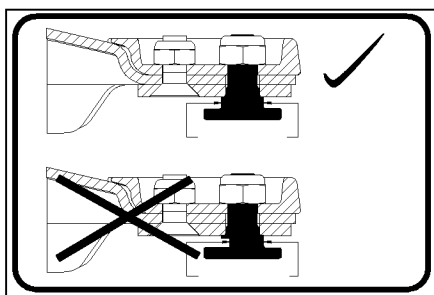

3

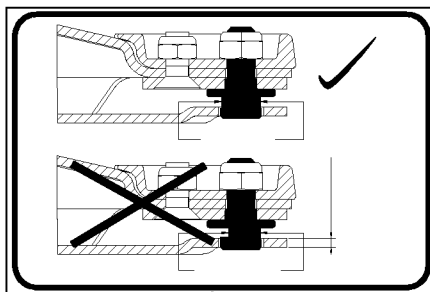

4

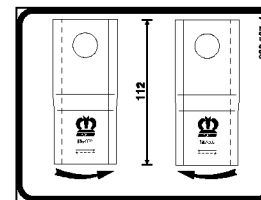

5

- D** Absperrhahn bei Transport schließen. 529 180-2
- E** Bloquear el grifo de cierre antes del transporte.
- F** Fermer le robinet d'arrêt avant le transport.
- GB** Close valve when transporting or servicing machine.
- I** Fermare la chiavetta d'arresto prima del trasporto.

6

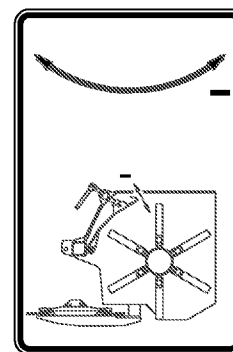

7



ID-NR.	TAFEL	POS.	ID-NR.	TAFEL	POS.	ID-NR.	TAFEL	POS.	ID-NR.	TAFEL	POS.	ID-NR.	TAFEL	POS.
ID-NO.	DIAG.	POS.	ID-NO.	DIAG.	POS.	ID-NO.	DIAG.	POS.	ID-NO.	DIAG.	POS.	ID-NO.	DIAG.	POS.
00 062 057 1	3.0	6	00 253 043 1	10.0	6	00 253 413 0	5.0	47	00 255 440 1	5.0	11	00 900 614 0	3.0	24
00 063 125 0	1.0	2	00 253 043 1	11.0	10	00 253 414 0	5.0	47	00 255 451 0	5.0	4	00 900 614 0	5.0	1
00 139 054 0	1.0	28	00 253 044 0	10.0	11	00 253 452 0	3.0	36	00 255 497 1	15.0	7	00 900 614 0	8.0	16
00 139 178 0	1.0	27	00 253 045 1	11.0	4	00 253 500 0	10.0	7	00 255 498 1	15.0	3	00 900 634 0	3.0	1
00 139 427 0	8.0	21	00 253 046 1	11.0	16	00 253 500 0	11.0	9	00 255 499 1	15.0	4	00 900 634 0	10.0	14
00 139 474 0	1.0	9	00 253 047 0	10.0	12	00 253 502 0	10.0	3	00 255 501 0	6.0	21	00 900 636 0	1.0	13
00 139 475 0	1.0	10	00 253 047 0	11.0	13	00 253 502 0	11.0	3	00 256 015 1	8.0	61	00 900 636 0	6.0	10
00 139 888 0	10.0	10	00 253 052 1	10.0	2	00 253 510 1	3.0	16	00 256 101 2	8.0	48	00 900 636 0	8.0	31
00 139 888 0	11.0	6	00 253 052 1	11.0	2	00 253 515 1	3.0	13	00 256 103 0	8.0	52	00 900 636 0	9.0	28
00 139 889 0	10.0	10	00 253 053 0	9.0	31	00 253 516 1	3.0	7	00 256 104 0	8.0	25	00 900 636 0	11.0	15
00 139 889 0	11.0	6	00 253 108 0	11.0	5	00 253 547 0	9.0	21	00 256 109 2	8.0	43	00 900 655 0	8.0	56
00 144 141 2	1.0	5	00 253 126 0	1.0	30	00 253 551 0	1.0	6	00 256 111 3	8.0	45	00 900 655 0	11.5	6
00 145 156 2	2.0	7	00 253 127 0	1.0	29	00 253 563 0	1.0	8	00 256 112 0	8.0	47	00 900 656 0	11.5	4
00 153 088 0	3.0	38	00 253 145 0	2.0	5	00 253 564 0	2.0	21	00 256 113 0	8.0	18	00 900 657 0	6.0	1
00 250 373 0	3.0	9	00 253 166 0	2.0	12	00 253 565 1	2.0	17	00 256 173 0	8.0	55	00 900 657 0	6.0	17
00 250 500 0	6.0	12	00 253 168 0	8.0	40	00 253 601 0	3.0	4	00 256 186 0	8.0	13	00 900 658 0	6.0	3
00 250 745 0	5.0	41	00 253 170 0	8.0	65	00 253 619 0	3.0	34	00 256 187 1	8.0	37	00 900 673 0	5.0	18
00 250 831 1	5.0	6	00 253 179 0	2.0	1	00 253 623 0	3.0	27	00 256 189 0	8.0	29	00 900 673 0	6.0	22
00 250 851 0	5.0	34	00 253 182 1	3.0	35	00 253 626 0	5.0	48	00 256 191 0	8.0	24	00 900 675 0	8.0	59
00 251 241 1	2.0	8	00 253 183 0	3.0	31	00 253 628 1	5.0	38	00 256 192 0	8.0	28	00 901 028 0	5.0	5
00 253 000 0	7.0	10	00 253 191 0	2.0	4	00 253 632 0	5.0	24	00 256 193 0	8.0	36	00 901 421 1	2.0	2
00 253 015 3	9.0	14	00 253 208 0	1.0	18	00 253 637 0	5.0	31	00 256 194 0	8.0	42	00 901 422 0	5.0	49
00 253 016 3	9.0	23	00 253 329 0	1.0	34	00 253 643 0	3.0	3	00 256 210 1	3.0	16	00 901 423 0	5.0	22
00 253 017 1	9.0	26	00 253 334 0	6.0	13	00 253 646 0	5.0	23	00 256 221 0	3.0	22	00 901 435 0	5.0	35
00 253 020 1	9.0	17	00 253 342 0	9.0	40	00 253 660 0	4.0	8	00 256 222 0	3.0	23	00 901 451 0	3.0	28
00 253 021 1	9.0	36	00 253 343 0	9.0	40	00 253 661 0	4.0	1	00 256 223 0	3.0	22	00 901 454 0	11.5	4
00 253 022 1	9.0	37	00 253 356 0	6.0	16	00 253 670 0	5.0	38	00 256 224 0	3.0	23	00 901 512 0	3.0	14
00 253 023 1	9.0	5	00 253 361 0	6.0	11	00 253 671 0	5.0	28	00 256 354 1	5.0	39	00 902 401 0	1.0	22
00 253 024 1	9.0	7	00 253 362 0	6.0	11	00 253 672 0	5.0	36	00 256 355 1	5.0	50	00 903 045 0	5.0	17
00 253 025 1	9.0	10	00 253 363 0	5.0	25	00 253 672 0	5.0	46	00 256 358 0	5.0	50	00 903 073 1	8.0	46
00 253 026 1	9.0	4	00 253 364 0	1.0	16	00 253 673 0	5.0	27	00 256 382 0	11.5	7	00 903 205 0	1.0	11
00 253 027 1	9.0	1	00 253 365 0	1.0	24	00 253 674 0	5.0	48	00 256 385 0	11.5	1	00 903 205 0	3.0	17
00 253 028 1	9.0	9	00 253 366 0	1.0	24	00 255 242 0	6.0	24	00 256 390 0	1.0	39	00 904 027 0	5.0	37
00 253 030 0	9.0	24	00 253 371 0	2.0	1	00 255 286 0	6.0	7	00 256 390 0	11.0	18	00 904 045 3	10.0	9
00 253 033 0	9.0	35	00 253 373 0	2.0	7	00 255 304 0	3.0	37	00 274 949 0	5.0	40	00 904 045 3	11.0	7
00 253 034 2	8.0	50	00 253 378 2	4.0	2	00 255 310 0	5.0	20	00 461 846 0	1.0	37	00 904 062 0	9.0	30
00 253 040 1	10.0	15	00 253 379 2	4.0	2	00 255 319 1	5.0	12	00 900 244 0	2.0	20	00 904 071 1	9.0	30
00 253 040 1	11.0	17	00 253 401 0	3.0	4	00 255 329 1	5.0	3	00 900 335 1	7.0	1	00 904 708 0	5.0	21
00 253 042 1	10.0	8	00 253 405 0	5.0	31	00 255 330 1	5.0	7	00 900 335 1	9.0	16	00 904 745 1	5.0	42
00 253 042 1	11.0	8	00 253 412 0	5.0	26	00 255 331 1	5.0	10	00 900 612 0	7.0	3	00 904 882 1	4.0	3

ID-NR. ID-NO.	TAFEL DIAG.	POS. POS.	ID-NR. ID-NO.	TAFEL DIAG.	POS. POS.	ID-NR. ID-NO.	TAFEL DIAG.	POS. POS.	ID-NR. ID-NO.	TAFEL DIAG.	POS. POS.	ID-NR. ID-NO.	TAFEL DIAG.	POS. POS.
00 905 755 0	6.0	18	00 909 909 1	11.0	14	00 911 023 0	8.0	3	00 918 447 0	2.0	13	00 934 954 0	1.0	17
00 906 007 1	9.0	33	00 909 910 1	3.0	29	00 911 024 0	8.0	3	00 918 793 0	2.0	13	00 935 716 0	6.0	14
00 906 040 1	8.0	20	00 909 910 1	6.0	4	00 911 130 0	8.0	35	00 919 103 0	12.0	22	00 936 049 0	9.0	6
00 906 132 0	8.0	19	00 909 910 1	8.0	57	00 911 132 0	8.0	35	00 919 103 0	13.0	22	00 936 339 1	8.0	1
00 906 404 0	9.0	22	00 909 910 1	9.0	29	00 911 133 0	8.0	35	00 919 105 0	1.0	21	00 936 359 0	8.0	9
00 906 948 0	10.0	1	00 909 910 1	11.5	8	00 911 133 0	9.0	8	00 919 105 0	3.0	10	00 936 568 0	8.0	58
00 906 948 0	11.0	1	00 909 912 1	5.0	16	00 911 134 0	8.0	35	00 919 376 0	2.0	23	00 936 568 0	9.0	25
00 908 225 0	3.0	8	00 909 912 1	6.0	23	00 911 136 1	8.0	35	00 919 603 0	2.0	24	00 937 500 0	8.0	44
00 908 515 0	1.0	23	00 909 912 1	7.0	2	00 911 160 0	8.0	7	00 919 751 0	2.0	19	00 937 502 0	9.0	3
00 908 536 4	9.0	11	00 909 912 1	8.0	60	00 911 162 0	8.0	7	00 919 829 0	8.0	14	00 937 576 0	9.0	15
00 908 701 0	3.0	30	00 910 303 1	5.0	45	00 911 164 0	8.0	7	00 920 891 0	2.0	18	00 937 578 0	9.0	19
00 908 701 0	4.0	5	00 910 315 3	5.0	43	00 911 541 0	8.0	51	00 921 019 1	2.0	25	00 937 579 0	9.0	18
00 908 701 0	9.0	12	00 910 347 0	4.0	7	00 911 659 0	8.0	23	00 921 046 1	2.0	15	00 937 581 0	8.0	54
00 908 701 0	10.0	4	00 910 351 1	5.0	13	00 911 668 0	8.0	6	00 921 067 1	2.0	14	00 937 583 0	8.0	41
00 908 701 0	11.0	12	00 910 362 0	5.0	19	00 911 673 0	8.0	2	00 921 077 1	2.0	22	00 937 721 0	9.0	32
00 908 701 0	11.5	3	00 910 413 0	5.0	8	00 911 680 0	8.0	49	00 921 145 0	2.0	26	00 937 727 0	8.0	15
00 908 704 1	2.0	28	00 910 414 0	1.0	14	00 912 287 1	1.0	4	00 921 171 1	2.0	27	00 938 686 0	1.0	12
00 908 704 1	5.0	14	00 910 414 0	3.0	20	00 912 500 1	1.0	19	00 921 206 0	2.0	16	00 939 100 0	14.0	6
00 908 706 0	2.0	3	00 910 506 1	3.0	29	00 912 508 0	8.0	32	00 921 234 0	2.0	23	00 939 180 2	15.0	6
00 908 706 0	3.0	26	00 910 506 1	4.0	4	00 912 641 2	1.0	35	00 922 650 0	1.0	1	00 939 410 2	14.0	3
00 908 706 0	5.0	9	00 910 506 1	11.5	2	00 912 670 1	3.0	12	00 924 261 0	3.0	21	00 939 471 1	14.0	1
00 908 716 1	5.0	15	00 910 512 2	1.0	36	00 912 671 2	3.0	5	00 925 017 0	5.0	30	00 939 567 1	15.0	5
00 908 716 1	6.0	15	00 910 512 2	3.0	11	00 912 672 1	2.0	11	00 925 031 0	5.0	29	00 939 572 0	14.0	4
00 908 721 0	1.0	25	00 910 514 1	3.0	40	00 912 672 1	3.0	33	00 925 104 0	5.0	32	00 940 082 2	6.0	20
00 908 721 0	3.0	15	00 910 516 1	1.0	31	00 912 675 2	2.0	6	00 925 130 0	5.0	33	00 942 196 1	14.0	2
00 908 758 0	1.0	15	00 910 603 0	3.0	25	00 912 711 0	8.0	33	00 925 203 0	8.0	5	00 942 197 1	14.0	5
00 908 758 0	3.0	19	00 910 603 0	5.0	2	00 912 714 2	3.0	41	00 925 303 2	10.0	16	00 942 296 0	15.0	2
00 908 758 0	5.0	44	00 910 603 0	7.0	4	00 912 718 2	1.0	7	00 926 101 0	7.0	10	00 942 301 0	15.0	2
00 908 758 0	10.0	5	00 910 642 0	6.0	2	00 912 722 1	12.0	24	00 926 101 0	8.0	65	00 942 303 0	15.0	1
00 908 758 0	11.0	11	00 910 649 0	1.0	26	00 912 722 1	13.0	24	00 926 101 0	9.0	40	00 942 308 1	15.0	1
00 909 503 1	4.0	6	00 910 653 1	3.0	32	00 912 747 2	1.0	32	00 930 103 0	8.0	22	00 942 346 1	15.0	1
00 909 548 0	6.0	8	00 910 844 0	3.0	39	00 915 001 0	8.0	39	00 930 137 0	8.0	8	00 942 347 1	15.0	1
00 909 611 0	9.0	20	00 910 865 1	2.0	10	00 915 016 0	6.0	19	00 930 167 0	8.0	4	00 949 233 0	13.0	23
00 909 904 1	3.0	18	00 910 899 0	1.0	20	00 915 016 0	8.0	26	00 930 338 0	8.0	34	00 949 272 0	13.0	27
00 909 908 1	8.0	17	00 910 970 0	8.0	10	00 915 017 0	8.0	27	00 930 341 0	9.0	2	00 949 273 1	12.0	5
00 909 909 1	3.0	2	00 910 972 0	8.0	10	00 915 105 0	8.0	38	00 930 568 0	8.0	11	00 949 281 0	12.0	52
00 909 909 1	6.0	9	00 910 973 0	8.0	10	00 915 108 0	9.0	13	00 934 052 0	6.0	6	00 949 281 0	13.0	52
00 909 909 1	8.0	30	00 910 992 0	8.0	53	00 915 122 0	8.0	12	00 934 554 0	1.0	33	00 949 352 0	12.0	53
00 909 909 1	9.0	27	00 910 993 0	8.0	53	00 917 004 1	1.0	38	00 934 608 0	6.0	5	00 949 354 0	12.0	26
00 909 909 1	10.0	13	00 911 022 0	8.0	3	00 917 104 1	1.0	3	00 934 901 0	2.0	9	00 949 356 0	12.0	4



**Verwenden Sie nur**

**Original-KRONE-Ersatzteile!**

**Das gibt Sicherheit und spart Kosten!**

---

Original-KRONE-Ersatzteile bieten die Garantie für höchste Verschleißfestigkeit, lange Lebensdauer und preiswerten Einkauf!

Sie bekommen bei Krone nur Materialien in einwandfreier Qualität und absolut passend für Ihre KRONE-Maschinen. Bei Verwendung von Original-KRONE-Ersatzteilen entspricht das Gerät in Funktion und Arbeitsweise wieder der ursprünglichen Ausführung!

Imitationen und Kopien von Teilen, speziell auf dem Sektor Verschleißteile halten nicht das, was sie vom Aussehen vielleicht versprechen. Material-Qualität kann man schlecht optisch prüfen - daher größte Vorsicht bei Billigangeboten!

**Darum lieber gleich  
Original-KRONE-Ersatzteile!**

**Ersatzteil-Katalog auch  
auf CD-ROM erhältlich!**

**Use**

**Original-KRONE parts only**

**This will increase operational reliability  
and help to save costs!**

---

Original-KRONE-spare parts give you the guarantee of maximum resistance to wear, long life and low prices!

KRONE provides you with parts of first-rate quality which are perfectly suitable for your KRONE machine. By using original KRONE parts you can be sure that function and mode of operation are again as satisfactory as on a new machine!

Imitations and copies of parts, in particular working parts, are not as reliable as they seem to be! The quality of material can hardly be checked with the eye - it is therefore not advisable to purchase imitation parts even if these are cheaper.

**In any case it's better  
to use original KRONE parts!**

**Spare parts list also  
available as CD-ROM!**

**N'utiliser que**

**des pièces de rechange  
d'origine KRONE!**

**Vous augmentez ainsi la sécurité de  
fonctionnement et vous réduisez  
considérablement vos coûts!**

---

Les pièces de rechange d'origine Krone vous donnent la sécurité d'une exceptionnelle résistance à l'usure, d'une longue durée d'utilisation et de prix avantageux.

KRONE vous offre uniquement des pièces de première qualité parfaitement adaptées à votre machine KRONE. En utilisant des pièces de rechange d'origine KRONE vous pouvez être sûr que fonctionnement et le mode de travail sont identiques à ceux d'une machine nouvelle.

Les imitations et copies de pièces, tout particulièrement des pièces d'usure, ne tiennent pas ce qu'elles promettent par leur apparence! En effet il n'est guère possible de vérifier visuellement la qualité d'une matière. Il est donc prudent de juger avec scepticisme les pièces de rechange à bas prix!

**De toute façon il est raisonnable de donner la préférence au  
pièces de rechange d'origine KRONE!**

**Catalogue de pièces de rechange  
également disponible sur CD-ROM!**

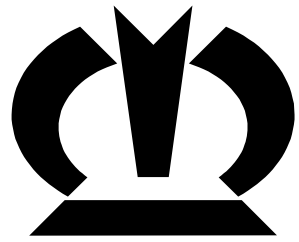

# ***KRONE***

**... konsequent, kompetent**

## **Maschinenfabrik Bernard Krone GmbH**

Heinrich-Krone-Straße 10, D-48480 Spelle  
Postfach 11 63, D-48478 Spelle

Phone +049 (0) 59 77/935-0  
Fax +049 (0) 59 77/935-339 - Zentrale  
Fax +049 (0) 59 77/935-239 - ET-Lager

Internet: <http://www.krone.de>  
eMail: [info.ldm@krone.de](mailto:info.ldm@krone.de)